EM88F752N

**8-BIT
Microcontroller**

**Product
Specification**

DOC. VERSION 1.5

ELAN MICROELECTRONICS CORP.

February 2018



Trademark Acknowledgments:

IBM is a registered trademark and PS/2 is a trademark of IBM.

Windows is a trademark of Microsoft Corporation.

ELAN and ELAN logo  are trademarks of ELAN Microelectronics Corporation.

Copyright © 2018 by ELAN Microelectronics Corporation

All Rights Reserved

Printed in Taiwan

The contents of in this specification are subject to change without notice. ELAN Microelectronics assumes no responsibility concerning the accuracy, adequacy, or completeness of this specification. ELAN Microelectronics makes no commitment to update, or to keep current the information and material contained in this specification. Such information and material may change to conform to each confirmed order.

In no event shall ELAN Microelectronics be made responsible to any claims attributed to errors, omissions, or other inaccuracies in the information or material contained in this specification. ELAN Microelectronics shall not be liable for direct, indirect, special incidental, or consequential damages arising out of the use of such information or material.

The software (if any) described in this specification is furnished under a license or nondisclosure agreement, and may be used or copied only in accordance with the terms of such agreement.

ELAN Microelectronics products are not intended for use in life support appliances, devices, or systems. Use of ELAN Microelectronics product in such applications is not supported and is prohibited.

NO PART OF THIS SPECIFICATION MAY BE REPRODUCED OR TRANSMITTED IN ANY FORM OR BY ANY MEANS WITHOUT THE EXPRESS WRITTEN PERMISSION OF ELAN MICROELECTRONICS.



ELAN MICROELECTRONICS CORPORATION

Headquarters:

No. 12, Innovation 1st Road
Hsinchu Science Park
Hsinchu, TAIWAN 30076
Tel: +886 3 563-9977
Fax: +886 3 563-9966
webmaster@emc.com.tw
<http://www.emc.com.tw>

Hong Kong:

Elan (HK) Microelectronics Corporation, Ltd.
Flat A, 19F., World Tech Centre
95 How Ming Street, Kwun Tong
Kowloon, HONG KONG
Tel: +852 2723-3376
Fax: +852 2723-7780

USA:

Elan Information Technology Group (U.S.A.)
PO Box 601
Cupertino, CA 95015
U.S.A.
Tel: +1 408 366-8225
Fax: +1 408 366-8225

Shenzhen:

Elan Microelectronics Shenzhen, Ltd.
8A Floor, Microprofit Building
Gaoxin South Road6
Shenzhen Hi-Tech Industrial Park
South Area, Shenzhen
CHINA 518057
Tel: +86 755 2601-0565
Fax: +86 755 2601-0500
elan-sz@elanic.com.cn

Shanghai:

Elan Microelectronics Shanghai, Ltd.
6F, Ke Yuan Building
No. 5Bibo Road
Zhangjiang Hi-Tech Park
Shanghai, CHINA 201203
Tel: +86 21 5080-3866
Fax: +86 21 5080-0273
elan-sh@elanic.com.cn

Contents

1	General Description	1
2	Features	2
2.1	Selection Table	3
3	Pin Configuration	4
4	Pin Description	6
5	Functional Block Diagram	9
6	Function Description	10
6.1	Operational Registers	10
6.1.1	R0: IAR (Indirect Addressing Register)	10
6.1.2	R1: BSR (Bank Selection Control Register).....	10
6.1.3	R2: PCL (Program Counter Low)	10
6.1.4	R3: SR (Status Register)	16
6.1.5	R4: RSR (RAM Select Register)	17
6.1.6	Bank 0 R5 ~ RA (Port 5 ~ Port A).....	17
6.1.7	Bank 0 RB IOCR5 (I/O Port 5 Control Register)	17
6.1.8	Bank 0 RC IOCR6 (I/O Port 6 Control Register)	17
6.1.9	Bank 0 RE: OMCR (Operating Mode Control Register).....	17
6.1.10	Bank 0 RF: EIESCR (External Interrupt Edge Select Control Register)	20
6.1.11	Bank 0 R10: WUCR1 (Wake-up Control Register 1)	20
6.1.12	Bank 0 R11: WUCR2 (Wake-up Control Register 2).....	21
6.1.13	Bank 0 R12: WUCR3 (Wake-up Control Register 3)	22
6.1.14	Bank 0 R13: (Reserved).....	22
6.1.15	Bank 0 R14: SFR1 (Status Flag Register 1)	22
6.1.16	Bank 0 R15: SFR2 (Status Flag Register 2)	23
6.1.17	Bank 0 R16: SFR3 (Status Flag Register 3)	23
6.1.18	Bank 0 R17: SFR4 (Status Flag Register 4)	24
6.1.19	Bank 0 R18: (Reserved).....	24
6.1.20	Bank 0 Bank 0 R19: SFR6 (Status Flag Register 6)	25
6.1.21	Bank 0 R1A: (Reserved)	25
6.1.22	Bank 0 R1B: IMR1 (Interrupt Mask Register 1).....	25
6.1.23	Bank 0 R1C: IMR2 (Interrupt Mask Register 2)	26
6.1.24	Bank 0 R1D: IMR3 (Interrupt Mask Register 3)	26
6.1.25	Bank 0 R1E: IMR4 (Interrupt Mask Register 4).....	27
6.1.26	Bank 0 R1F: (Reserved).....	28
6.1.27	Bank 0 R20: IMR6 (Interrupt Mask Register 6)	28
6.1.28	Bank 0 R21: WDTCSR (Watchdog Timer Control Register)	28
6.1.29	Bank 0 R22: TCCCR (TCC Control Register)	29
6.1.30	Bank 0 R23: TCCD (TCC Data Register).....	30
6.1.31	Bank 0 R24: TC1CR1 (Timer/Counter 1 Control Register 1)	30
6.1.32	Bank 0 R25: TC1CR2 (Timer/Counter 1 Control Register 2)	31

6.1.33	Bank 0 R26: TC1DA (Timer/Counter 1 Data Buffer A)	32
6.1.34	Bank 0 R27: TC1DB (Timer/Counter 1 Data Buffer B)	32
6.1.35	Bank 0 R28: TC2CR1 (Timer/Counter 2 Control Register 1)	33
6.1.36	Bank 0 R29: TC2CR2 (Timer/Counter 2 Control Register 2)	34
6.1.37	Bank 0 R2A: TC2DA (Timer/Counter 2 Data Buffer A)	35
6.1.38	Bank 0 R2B: TC2DB (Timer/Counter 2 Data Buffer B)	35
6.1.39	Bank 0 R2C: TC3CR1 (Timer/Counter 3 Control Register 1)	36
6.1.40	Bank 0 R2D: TC3CR2 (Timer/Counter 3 Control Register 2)	37
6.1.41	Bank 0 R2E: TC3DA (Timer/Counter 3 Data Buffer A)	38
6.1.42	Bank 0 R2F: TC3DB (Timer/Counter 3 Data Buffer B)	38
6.1.43	Bank 0 R30: I2CCR1 (I2C Status and Control Register 1)	38
6.1.44	Bank 0 R31: I2CCR2 (I2C Status and Control Register 2)	39
6.1.45	Bank 0 R32: I2CSA (I2C Slave Address Register)	40
6.1.46	Bank 0 R33: I2CDB (I2C Data Buffer Register)	41
6.1.47	Bank 0 R34: I2CDAL (I2C Device Address Register)	41
6.1.48	Bank 0 R35: I2CDAH (I2C Device Address Register)	41
6.1.49	Bank 0 R36 ~R3D: (Reserved)	41
6.1.50	Bank 0 R3E: ADCR1 (ADC Control Register 1)	41
6.1.51	Bank 0 R3F: ADCR2 (ADC Control Register 2)	43
6.1.52	Bank 0 R40: ADISR (Analog to Digital Converter Input Channel Selection Register)	44
6.1.53	Bank 0 R41: ADER1 (Analog to Digital Converter Input Control Register 1) ..	45
6.1.54	Bank 0 R42: (Reserved)	46
6.1.55	Bank 0 R43: ADDL (Low Byte of Analog to Digital Converter Data)	46
6.1.56	Bank 0 R44: ADDH (High Byte of Analog to Digital Converter Data)	46
6.1.57	Bank 0 R45 ADCVL (Low Byte of Analog to Digital Converter Comparison) ..	46
6.1.58	Bank 0 R46 ADCVH (High Byte of Analog to Digital Converter Comparison) ..	47
6.1.59	Bank 0 R47 ~ R4F (Reserved)	47
6.1.60	Bank 1 R5 IOCR8 (I/O Port 8 Control Register)	47
6.1.61	Bank 1 R6 ~ R7 (Reserved)	47
6.1.62	Bank 1 R8: P5PHCR (Port 5 Pull-high Control Register)	47
6.1.63	Bank 1 R9: P6PHCR (Port 6 Pull-high Control Register)	48
6.1.64	Bank 1 RA: P8PHCR (Port 8 Pull-high Control Register)	48
6.1.65	Bank 1 RB: P5PLCR (Port 5 Pull-low Control Register)	49
6.1.66	Bank 1 RC: P6PLCR (Port 6 Pull-low Control Register)	49
6.1.67	Bank 1 RD: P8PLCR (Ports8 Pull-low Control Register)	50
6.1.68	Bank 1 RE: P5HDSCR (Port 5 High Drive/Sink Control Register)	50
6.1.69	Bank 1 RF: P6HDSCR (Port 6 High Drive/Sink Control Register)	50
6.1.70	Bank 1 R10: P8HDSCR (Port 8 High Drive/Sink Control Register)	51
6.1.71	Bank 1 R11: P5ODCR (Port 5 Open-Drain Control Register)	51
6.1.72	Bank 1 R12: P6ODCR (Port 6 Open-Drain Control Register)	51
6.1.73	Bank 1 R13: P8ODCR (Port 8 Open-Drain Control Register)	52
6.1.74	Bank 1 R14: DeadTCR (Dead Time Control Register)	52
6.1.75	Bank 1 R15: DeadTR (Dead Time Register)	53
6.1.76	Bank 1 R16: PWMSCR (PWM Source Clock Control Register)	53
6.1.77	Bank 1 R17: PWMACR (PWMA Control Register)	53

6.1.78	Bank 1 R18: PRDAL (Low Byte of PWMA Period)	54
6.1.79	Bank 1 R19: PRDAH (High Byte of PWMA Period)	55
6.1.80	Bank 1 R1A: DTAL (Low Byte of PMWA Duty)	55
6.1.81	Bank 1 R1B: DTAH (High Byte of PMWA Duty)	56
6.1.82	Bank 1 R1C: TMRAL (Low Byte of TimerA)	56
6.1.83	Bank 1 R1D: TMRAH (High byte of Timer A)	56
6.1.84	Bank 1 R1E: PWMBCR (PWMB Control Register)	56
6.1.85	Bank 1 R1F: PRDBL (Low Byte of PWMB Period)	57
6.1.86	Bank 1 R20: PRDBH (High Byte of PWMB period).....	57
6.1.87	Bank 1 R21: DTBL (Low Byte of PMWB Duty)	58
6.1.88	Bank 1 R22: DTBH (High Byte of PMWB Duty)	58
6.1.89	Bank1 R23: TMRBL (Low Byte of Timer B).....	58
6.1.90	Bank 1 R24: TMRBH (High Byte of Timer B)	58
6.1.91	Bank 1 R25 ~ R39: (Reserved)	58
6.1.92	Bank 1 R40: WCR (Watch Timer Control Register)	59
6.1.93	Bank1 R41~R43: (Reserved)	59
6.1.94	Bank 1 R44: FLKR (Flash Key Register for Table Write Use).....	59
6.1.95	Bank 1 R45: TBPTL (Table Point Low Register)	59
6.1.96	Bank 1 R46: TBPTH (Table Point High Register).....	60
6.1.97	Bank 1 R47: STKMON (Stack Point).....	60
6.1.98	Bank 1 R48: PCH (Program Counter High)	60
6.1.99	Bank 1 R49: LVDCR (Low Voltage Detector Control Register).....	61
6.1.100	Bank 1 R4D TBWCR (Table Write Control Register)	61
6.1.101	Bank 1 R4E: 0cL (Table Write Start Address Low Byte).....	62
6.1.102	Bank 1 R4F: TBWAH (Table Write Start Address High Byte)	62
6.1.103	Bank 2 R5 ~ R46 (Reserved)	62
6.1.104	Bank 2 R47 LOCKPR (Lock Page Number Register)	62
6.1.105	Bank 2 R48 LOCKCR (Lock Control Register)	63
6.1.106	R50~R7F, Banks 0~3 R80~RFF	63
6.2	TCC/WDT and Prescaler	64
6.3	I/O Ports	66
6.4	Reset and Wake-up	70
6.4.1	Reset	70
6.4.2	Status of RST, T, and P of Status Register	74
6.5	Interrupt	90
6.6	A/D Converter	92
6.6.1	ADC Data Register	93
6.6.2	A/D Sampling Time.....	93
6.6.3	A/D Conversion Time	94
6.6.4	ADC Operation during Sleep Mode.....	95
6.6.5	Programming Process/Considerations.....	95
6.6.6	Programming Process for Detecting Internal VDD.....	96
6.7	Timer	98
6.7.1	Timer/Counter Mode.....	99
6.8.2	Window Mode.....	100

6.7.3	Capture Mode.....	101
6.7.4	Programmable Divider Output Mode and Pulse Width Modulation Mode ...	102
6.7.5	PDO.....	102
6.7.6	PWM.....	103
6.7.7	Buzzer Mode	103
6.8	PWM.....	104
6.8.1	Overview.....	105
6.8.2	Increment Timer Counter (TMRX: TMRAH/TMRAL, TMRBH/TMRBL).....	107
6.8.3	PWM Time Period (PRDX: PRDAL/H, PRDBL/H).....	107
6.8.4	PWM Duty Cycle (DTX: DTAH/DTAL or DTBH/DTBL).....	108
6.8.5	Dual PWM function.....	108
6.9	I2C Function	110
6.9.1	7-Bit Slave Address	112
6.9.2	10-Bit Slave Address	113
6.9.3	Master Mode.....	116
6.9.4	Slave Mode.....	116
6.10	Enhance Protect	117
6.10.1	Enhance Protect Programming	117
6.11	In Application Programing	119
6.11.1	In Application Programming	119
6.12	Low Voltage Detector.....	120
6.12.1	LVD.....	120
6.13	Oscillator.....	121
6.13.1	Oscillator Modes.....	121
6.13.2	Internal RC Oscillator Mode	122
6.14	Power-on Considerations.....	123
6.15	External Power-on Reset Circuit	123
6.16	Residue-Voltage Protection.....	123
6.17	Code Option	125
6.17.1	Code Option Register (Word 0).....	125
6.17.2	Code Option Register (Word 1).....	126
6.17.3	Code Option Register (Word 2).....	128
6.17.4	Code Option Register (Word 3).....	128
6.18	Instruction Set.....	130
7	Absolute Maximum Ratings.....	134
8	DC Electrical Characteristics.....	134
9	AC Electrical Characteristics.....	137

APPENDIX

A	Ordering and Manufacturing Information	138
B	Package Type.....	140
C	Package Information	141
	C.1 EM88F752NSO20	141
	C.2 EM88F752ND20	142
	C.3 EM88F752NSS20	143
	C.4 EM88F752ND16/AD16	144
	C.5 EM88F752NSO16/ASO16	145
	C.6 EM88F752NSS16/ASS16.....	146
D	Quality Assurance and Reliability	147
	D.1 Address Trap Detect	147
E	EM88F752N Program Pin List.....	148

Specification Revision History

Version	Revision Description	Date
1.0	Released version	2015/10/30
1.1	<ol style="list-style-type: none"> 1. Added a Note on the application 2. Added Figure 6-40 3. Modified the Bit Name of TPEPCR1, TPEPCR2 registers 4. Modified the description of the switch bits 5. Modified the description of TPAEP 6. Modified the Absolute Maximum Ratings 7. Modified the DC and AC Electrical Characteristics 8. Modified the Package Name 9. Modified the Name of the Registers 10. Modified the Oscillation Characteristics 11. Modified Table E-1 12. Modified Table Figure 6-3 13. Modified the description of IRC Oscillator Modes 14. Modified the description of Instruction Set 15. Deleted Figure 6-12 	2015/12/11
1.2	<ol style="list-style-type: none"> 1. Added User Application Note 2. Added a Note for Section 6.1.62 3. Added a Note for Section 6.1.65 4. Modified the package name in the Features, Package Information, Package Type, Program Pin List section 5. Modified the quantity of interrupts 6. Modified the Ordering and Manufacturing Information 7. Modified the register and package name on the Contents 8. Modified the definition of Bit in the registers(BSR, TBPTH, PCH, TBWAH) 9. Modified the name of the WCR register 10. Modified the description of Section 6.5 11. Modified the description of ADC Programming Process 12. Modified the description of I2C 7-Bit Slave Address 13. Modified the description of R2 	2016/06/02
1.3	<ol style="list-style-type: none"> 1. Added LVR1 Characteristics 2. Added LVD Description 3. Modified Chapter 6.2 Description 4. Modified Table 4 Bank 0 R0 Description 	2016/12/16

Version	Revision Description	Date
	5. Modified Table 4 Bank 0 RE Description 6. Modified Table 4 Bank 0 RE31 Description 7. Modified Chapter 8 Flash Characteristics 8. Modified Chapter 8 ADC Characteristics 9. Modified Chapter 6.12 Description 10. Modified Chapter 6.11 Description 11. Deleted LVR2, LVR3	
1.4	1. Added Crystal Characteristics 2. Modified AD Characteristics 3. Modified Data Memory Configuration 4. Modified Figure 3-1~3, Figure 5-1 5. Delete Description of Registers(TPEPCR1、TPEPCR2、TPCCR、TPCR1、TPCR2、TPCR3、TPAHTH、TPAHTL、TPALTH、TPALTL、TPAH、TPAL、TPSTH、TPSTL) 6. Deleted Description of Touch Key 7. Deleted Touch Key Characteristics	2017/10/02
1.5	1. Modified IRC Drift Rate table 2. Modified IRC mode selection table 3. Modified Code Option	2018/02/21



User Application Note

(Before using this IC, please look at the following description note, it includes important messages.)

1. Require 0.1 μ F capacitor between VDD and VSS
2. The PWMA (PWMB) duty/period is reloaded when PRDAL (PRDBL) register is updated.
3. The value in the dead-time register must be less than the value in the duty cycle register, in order to prevent unexpected behavior on both of the PWM outputs.
4. For ADC function, in order to obtain accurate values, it is necessary to avoid any data transition on the I/O pins during AD conversion.
5. If P50, P51 act as external interrupt, the pull-high (pull-low) function will automatically be disabled, the corresponding control bit is invalid.



1 General Description

The EM88F752N is an 8-bit microprocessor designed and developed with low-power, high-speed CMOS technology. It has an on-chip 2K*16-bit electrical flash memory.

Debug function is built in EM88F752N chip. User can read the program code from JTAG port and monitor the on chip register status, memory and program trace log on computer.

Using OCDS, user can develop their program for several flash types IC of ELAN



2 Features

- CPU configuration
 - 2K×16 bits Flash memory
 - (48+256) bytes general purpose register
 - More than 10 years data retention
 - 8-level stacks for subroutine nesting
 - Less than 1 mA at 5V/4MHz
 - Typically 15µA, at 3V/16kHz
 - Typically 22µA, at 3V/32kHz
 - Typically 1µA, during sleep mode
 - Level Voltage Reset
LVR: 2.7V, 1.8V (POR)
 - 1 set of 4 programmable Level Voltage Detector
LVD: 4.5V, 4.0V, 3.3V, 2.2V
- I/O port configuration
 - 3 bidirectional I/O ports: P5, P6, P8
 - 3 programmable pin change wake-up ports : P5, P6, P8
 - 3 programmable pull-down I/O ports: P5, P6, P8
 - 3 programmable pull-high I/O ports: P5, P6, P8
 - 3 programmable open-drain I/O ports: P5, P6, P8
 - 3 programmable high-sink/drive I/O ports: P5, P6, P8
- Operating voltage range:
 - 2.4V~5.5V at -40°C~85°C (industrial)
 - 2.1V~5.5V at 0°C~70°C (commercial)
- Operating frequency range (base on two clocks):

Main oscillator:

 - Crystal mode:
 - DC ~ 20MHz at 4.5V~5.5V
 - DC ~ 16MHz at 3.5V~5.5V
 - DC ~ 8MHz at 2.1V~5.5V
 - IRC mode:
 - DC ~ 20MHz at 4.5V~5.5V
 - DC ~ 16MHz at 3.5V~5.5V
 - DC ~ 8MHz at 2.1V~5.5V

Internal IRC Frequency	Drift Rate			
	Temp. (-40~+85°C)	Voltage (2.1~5.5V)	Process	Total
4 MHz	±2%	±1%	±1%	±4%
6 MHz	±2%	±1%	±1%	±4%
8 MHz	±2%	±1%	±1%	±4%
12 MHz	±2%	±1%	±1%	±4%
16 MHz	±2%	±1%	±1%	±4%
20 MHz	±2%	±1%	±1%	±4%

- Sub oscillator:**
- IRC mode: 16k/128kHz
 - Crystal Mode : 32.768kHz

- Peripheral configuration
 - 8-bit real time clock/counter (TCC) with selective signal sources, trigger edges, and overflow interrupt
 - Two Pulse Width Modulation (PWMA, PWMB) with 10-bit resolution shared with Timers A and B
 - Three 8-bit timers (TC1/TC2/TC3) with seven modes: Timer/Counter/Capture/Window/Buzzer/PWM/PDO (Programmable Divider Output) modes.
TC1+TC2 can be cascaded to one 16-bit counter/timer
 - 8+1 channels Analog-to-Digital Converter with 12-bit resolution
One of the channels is 1/2 VDD power detection
 - I²C function with 7/10 bits address and 8 bits data transmit/receive mode
 - Power down (Sleep) mode
- 20 available interrupts: (3 external, 17 internal)
 - Watch timer interrupt
 - External interrupt: EINT0,EINT1
 - TCCoverflow interrupt
 - TC1,TC2, TC3 overflow interrupt
 - Input-port status changed interrupt
 - ADC completion interrupt
 - PWMA, PWMB period/duty match completion
 - I²C transfer/receive/stop interrupt
 - LVD interrupt
 - System hold interrupt
- Single instruction cycle commands
- Five kinds of oscillation range in Crystal Mode

Crystal Range	Oscillator Mode
20 MHz ~ 12MHz	HXT1
12MHz ~ 6MHz	HXT2
6MHz ~ 1 MHz	XT
1MHz ~ 100 kHz	LXT1
32.768kHz	LXT2

- Programmable free running Watchdog Timer
 - Watchdog Timer: 16.5ms ± 5% with VDD =5V at 25°C, Temperature range ± 5% (-40°C ~+85°C)
 - Watchdog Timer:16.5ms ± 5% with VDD = 3V at 25°C, Temperature range ± 5% (-40°C~+85°C)
 - Two clocks per instruction cycle
- Package Type:
 - 20-pin SOP : 300mil EM88F752NSO20
 - 20-pin DIP : 300mil EM88F752ND20
 - 20-pin SSOP : 209mil EM88F752NSS20
 - 16-pin DIP : 300mil EM88F752ND16
 - 16-pin SSOP : 150mil EM88F752NSS16
 - 16-pin SOP : 150mil EM88F752NSO16
 - 16-pin DIP : 300mil EM88F752NAD16
 - 16-pin SSOP : 150mil EM88F752NASS16
 - 16-pin SOP : 150mil EM88F752NASO16

Note: These are all Green products which do not contain hazardous substances.

2.1 Selection Table

Features		EM88F752N	EM88F752N	EM88F752NA
Package Type		SSOP-20 SOP-20 DIP-20	SSOP-16 SOP-16 DIP-16	SSOP-16 SOP-16 DIP-16
Operation Voltage (V)		2.1~5.5 ⁽²⁾	2.1~5.5 ⁽²⁾	2.1~5.5 ⁽²⁾
Operating Speed	Oscillator Speed (MHz)	20	20	20
	Instruction cycle (ns)	100	100	100
On-chip Flash (16-bit Word)		2K	2K	2K
On-chip SRAM (8-bit Byte)		304	304	304
Watchdog Timer		Yes	Yes	Yes
RTC (Watch Time)		Yes	Yes	Yes
PWM Output	Resolution	10	10	10
	PWM Timer	2	1	2
	PWM Output	4	1	2
	Complement	Yes	No	No
	Dead-time	Yes	No	No
12-bit ADC	kSPS	100	100	100
	Power Detection	½ VDD	½ VDD	½ VDD
	Channels	8	7	8
	Sample-and-Hold	1	1	1
TCC		8 bits ^{*1}	8 bits ^{*1}	8 bits ^{*1}
TC1	Timer/Counter/Capture Window /PWM/PDO	8 bits ^{*1}	8 bits ^{*1}	8 bits ^{*1}
TC2		8 bits ^{*1}	8 bits ^{*1}	8 bits ^{*1}
TC3		8 bits ^{*1}	8 bits ^{*1}	8 bits ^{*1}
External Interrupts		2	2	2
Inter-integrated circuit (I2C)		1	1	1
I/OPins (Shared)	GPIO	18	14	14
	Direct LED Driver Pin	18	14	14
	Direct LED Driver Current (Typ.)	90mA ⁽¹⁾	90mA ⁽¹⁾	90mA ⁽¹⁾
Temp.	-40°C ~ 85°C	Yes ⁽²⁾	Yes ⁽²⁾	Yes ⁽²⁾

⁽¹⁾ Hi-sink current enable and output is GND +1.5V

⁽²⁾ Operating voltage: 2.4V~5.5V at -40°C ~85°C (Industrial)
2.1V~5.5V at 0°C~70°C (commercial)

Table 2-1 EM88F752N Selection Table

3 Pin Configuration

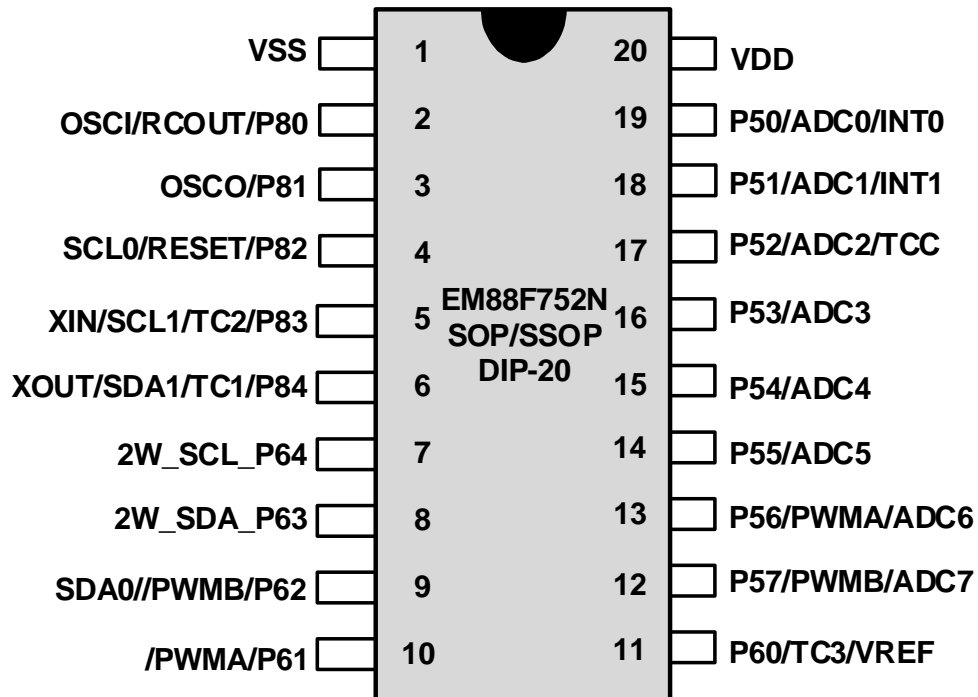

Figure 3-1 EM88F752N SOP/SSOP/DIP-20 Pin Assignment

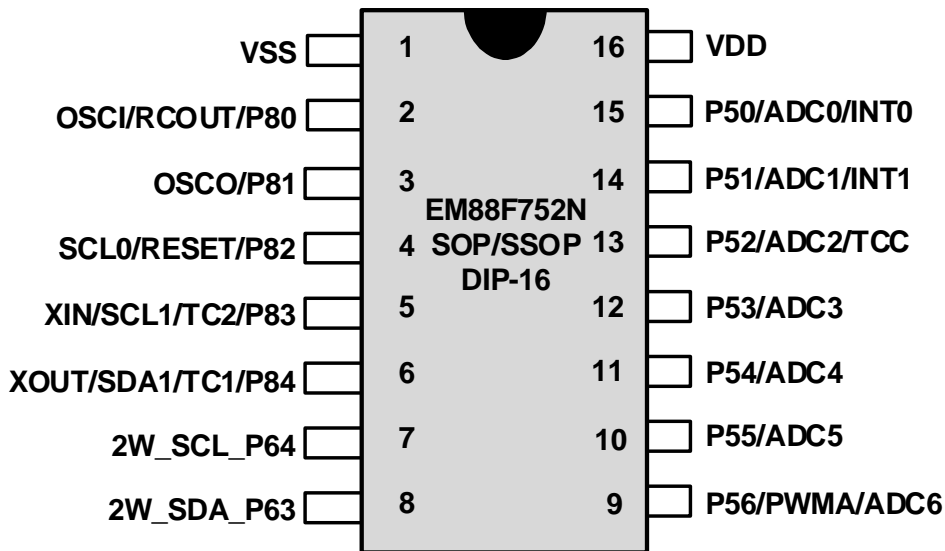

Figure 3-2 EM88F752N SOP/SSOP/DIP-16Pin Assignment

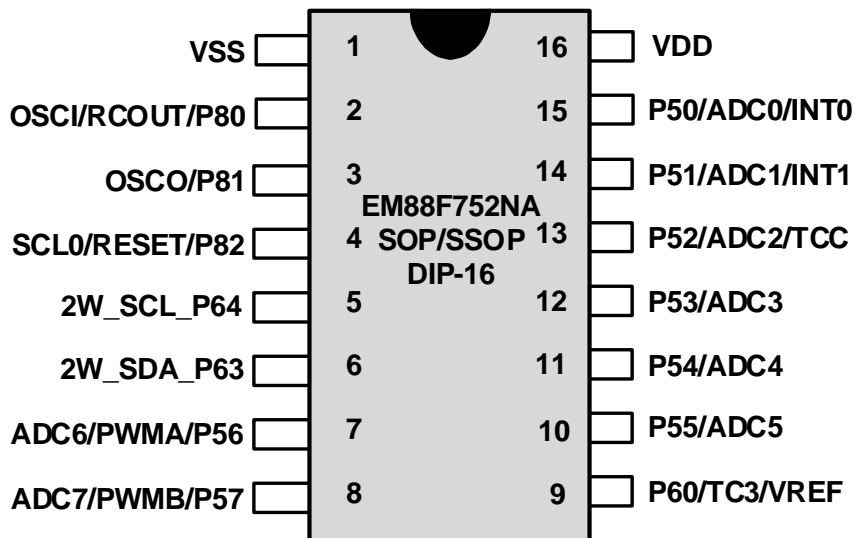

Figure 3-3 EM88F752NA SOP/SSOP/DIP-16Pin Assignment

4 Pin Description

Name	Function	Input Type	Output Type	Description
VDD	VDD	Power	–	Power
VSS	VSS	Power	–	Ground
P50/ADC0/INT0	P50	ST	CMOS	Bidirectional I/O pin with programmable pull-down, pull-high, open-drain, and pin change wake-up
	ADC0	AN	–	ADC Input 0
	INT0	ST	–	External Interrupt 0
P51/ADC1/INT1	P51	ST	CMOS	Bidirectional I/O pin with programmable pull-down, pull-high, open-drain, and pin change wake-up
	ADC1	AN	–	ADC Input 1
	INT1	ST	–	External Interrupt 1
P52/ADC2/TCC	P52	ST	CMOS	Bidirectional I/O pin with programmable pull-down, pull-high, open-drain, and pin change wake-up
	ADC2	AN	–	ADC Input 2
	TCC	ST	–	Real Time Clock/Counter clock input
P53/ADC3	P53	ST	CMOS	Bidirectional I/O pin with programmable pull-down, pull-high, open-drain, and pin change wake-up
	ADC3	AN	–	ADC Input 3
P54/ADC4	P54	ST	CMOS	Bidirectional I/O pin with programmable pull-down, pull-high, open-drain, and pin change wakeup
	ADC4	AN	–	ADC Input 4
P55/ADC5	P55	ST	CMOS	Bidirectional I/O pin with programmable pull-down, pull-high, open-drain, and pin change wake-up
	ADC5	AN	–	ADC Input 5
P56/PWMA/ADC6	P56	ST	CMOS	Bidirectional I/O pin with programmable pull-down, pull-high, open-drain, and pin change wake-up
	PWMA	–	CMOS	PWMA output
	ADC6	AN	–	ADC Input 6

Name	Function	Input Type	Output Type	Description
P57/PWMB/ADC7	P57	ST	CMOS	Bidirectional I/O pin with programmable pull-down, pull-high, open-drain, and pin change wake-up
	PWMB	–	CMOS	PWMB output
	ADC7	AN	–	ADC Input 7
P60/TC3/VREF	P60	ST	CMOS	Bidirectional I/O pin with programmable pull-down, pull-high, open-drain, and pin change wake-up
	TC3	ST	CMOS	8-bit Timer/Counter 3
	VREF	AN	–	Voltage reference for ADC
P61/ /PWMA	P61	ST	CMOS	Bidirectional I/O pin with programmable pull-down, pull-high, open-drain, and pin change wake-up
	/PWMA	–	CMOS	/PWMA output
P62/SDA0/ /PWMB	P62	ST	CMOS	Bidirectional I/O pin with programmable pull-down, pull-high, open-drain, and pin change wake-up
	SDA0	ST	CMOS	I ² C serial data line, open-drain
	/PWMB	–	CMOS	/PWMB output
P63/2W_SDA	P63	ST	CMOS	Bidirectional I/O pin with programmable pull-down, pull-high, open-drain, and pin change wake-up
	2W_SDA	ST	CMOS	On-chip Debug System data pin
P64/2W_SCL	P64	ST	CMOS	Bidirectional I/O pin with programmable pull-down, pull-high, open-drain, and pin change wake-up
	2W_SCL	ST	CMOS	On-chip Debug System clock pin
P80/RCOUT/OSCI	P80	ST	CMOS	Bidirectional I/O pin with programmable pull-down, pull-high, open-drain
	RCOUT	–	CMOS	Clock output of external RC oscillator (Open-drain)
	OSCI	XTAL	–	Clock input of crystal/resonator oscillator
P81/OSCO	P81	ST	CMOS	Bidirectional I/O pin with programmable pull-down, pull-high, open-drain
	OSCO	–	XTAL	Clock output of crystal/resonator oscillator

Name	Function	Input Type	Output Type	Description
P82/RESET/SCL0	P82	ST	CMOS	Bidirectional I/O pin with programmable pull-down, pull-high, open-drain
	RESET	ST	–	
	SCL0	ST	CMOS	I ² C Serial Clock Line. It is open-drain
P83/TC2/SCL1/XIN	P83	ST	CMOS	Bidirectional I/O pin with programmable pull-down, pull-high, open-drain
	TC2	ST	CMOS	8-bit Timer/Counter 2
	SCL1	ST	CMOS	I ² C Serial Clock Line. It is open-drain
	XIN	XTAL	–	Clock input of crystal/resonator oscillator
P84/TC1/SDA1/XOUT	P84	ST	CMOS	Bidirectional I/O pin with programmable pull-down, pull-high, open-drain
	TC1	ST	CMOS	8-bit Timer/Counter 1
	SDA1	ST	CMOS	I ² C Serial Data Line. It is open-drain
	XOUT	–	XTAL	Clock output of crystal/resonator oscillator

6 Function Description

6.1 Operational Registers

6.1.1 R0: IAR (Indirect Addressing Register)

R0 is not a physically implemented register. Its major function is to perform as an indirect addressing pointer. Any instruction using R0 as a pointer actually accesses data pointed by the RAM Select Register (R4).

6.1.2 R1: BSR (Bank Selection Control Register)

Bit 7	Bit 6	Bit 5	Bit 4	Bit 3	Bit 2	Bit 1	Bit 0
-	-	SBS1	SBS0	-	-	-	GBS0
0	0	R/W	R/W	0	0	0	R/W

Bits 7~6: Not used, set to "0" all the time.

Bits 5~4 (SBS1~SBS0): special register bank select bit. It is used to select Bank 0/1/2 of special register R5~R4F.

SBS1	SBS0	Special Register Bank
0	0	0
0	1	1
1	0	2
1	1	x

Bits 3~1: Not used, set to "0" all the time.

Bit 0 (GBS0): general register bank select bit. It is used to select Banks 0~1 of general register R80~RFF.

GBS0	RAM Bank
0	0
1	1

6.1.3 R2: PCL (Program Counter Low)

Bit 7	Bit 6	Bit 5	Bit 4	Bit 3	Bit 2	Bit 1	Bit 0
PC7	PC6	PC5	PC4	PC3	PC2	PC1	PC0
R/W	R/W	R/W	R/W	R/W	R/W	R/W	R/W

Bits 7~0 (PC7~PC0): The low byte of program counter.

- Depending on the device type, R2 and hardware stack are 15-bit wide. The structure is depicted in Figure 6-1.
- Generating 2K×16 bits on-chip Flash ROM addresses to the relative programming instruction codes. One program page is 4096 words long.
- R2 is set as all "0"s when under RESET condition.
- "JMP" instruction allows direct loading of the lower 12 program counter bits. Thus, "JMP" allows PC to go to any location within a page.
- "CALL" instruction loads the lower 12 bits of the PC, and the present PC value will add 1 and is pushed into the stack. Thus, the subroutine entry address can be located anywhere within a page.
- "LJMP" instruction allows direct loading of the lower 13 program counter bits. Therefore, "LJMP" allows PC to jump to any location within 8K (2^{13}).
- "LCALL" instruction loads the lower 13 bits of the PC, and then PC+1 is pushed into the stack. Thus, the subroutine entry address can be located anywhere within 8K (2^{13}).
- "RET" ("RETLK", "RETI") instruction loads the program counter with the contents of the top-level stack.
- "ADD R2, A" allows a relative address to be added to the current PC, and the ninth and above bits of the PC will increase progressively.
- "MOV R2, A" allows to load an address from the "A" register to the lower 8 bits of the PC, and the ninth and above bits of the PC won't be changed.
- Any instruction except "ADD R2,A" that is written to R2 (e.g. "MOV R2, A", "BC R2, 6", "INC R2",.....) will cause the ninth bit and the above bits (PC8~PC12) of the PC not change.
- All instructions are single instruction cycle ($F_{sys}/2$) except "LCALL", "LJMP" and the instruction corresponding to the operation on R2. Those instructions need two instruction cycles.

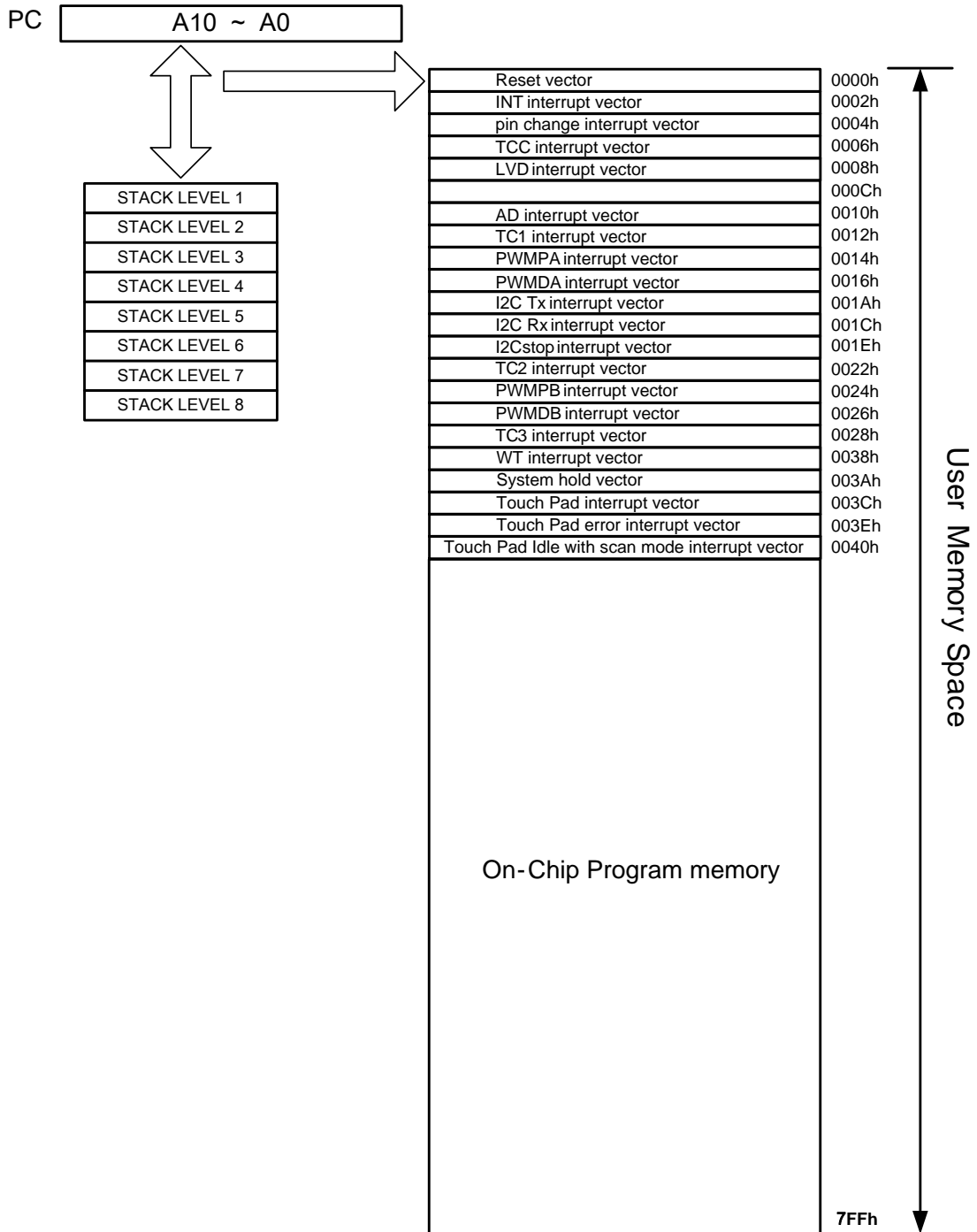

Figure 6-1 Program Counter Organization



Address	Bank 0	Bank 1	Bank 2
0X00	IAR (Indirect Addressing Register)		
0X01	BSR (Bank Selection Control Register)		
0X02	PCL (Program Counter Low)		
0X03	SR (Status Register)		
0X04	RSR (RAM Selection Register)		
0X05	Port 5	IOCR8	Reserved
0X06	Port 6	Reserved	Reserved
0X07	Reserved	Reserved	Reserved
0X08	Port 8	P5PHCR	Reserved
0X09	Reserved	P6PHCR	Reserved
0X0A	Reserved	P8PHCR	Reserved
0x0B	IOCR5	P5PLCR	Reserved
0X0C	IOCR6	P6PLCR	Reserved
0X0D	Reserved	P8PLCR	Reserved
0X0E	OMCR (Operating Mode Control Register)	P5HDSCR	Reserved
0X0F	EIESCR (External Interrupt Edge Select Control Register)	P6HDSCR	Reserved
0X10	WUCR1	P8HDSCR	Reserved
0X11	WUCR2	P5ODCR	Reserved
0X12	WUCR3	P6ODCR	Reserved
0X13	Reserved	P8ODCR	Reserved
0X14	SFR1 (Status Flag Register 1)	DeadTCR	Reserved
0X15	SFR2 (Status Flag Register 2)	DeadTR	Reserved
0X16	SFR3 (Status Flag Register 3)	PWMSCR	Reserved
0X17	SFR4 (Status Flag Register 4)	PWMACR	Reserved
0X18	Reserved	PRDAL	Reserved
0X19	SFR6 (Status Flag Register 6)	PRDAH	Reserved
0X1A	Reserved	DTAL	Reserved
0X1B	IMR1 (Interrupt Mask Register 1)	DTAH	Reserved
0X1C	IMR2 (Interrupt Mask Register 2)	TMRAL	Reserved
0X1D	IMR3 (Interrupt Mask Register 3)	TMRAH	Reserved
0X1E	IMR4 (Interrupt Mask Register 4)	PWMBKR	Reserved
0X1F	Reserved	PRDBL	Reserved
0X20	IMR6 (Interrupt Mask Register 6)	PRDBH	Reserved
0X21	WDTCR	DTBL	Reserved
0X22	TCCCR	DTBH	Reserved

Address	Bank 0	Bank 1	Bank 2
0X23	TCCD	TMRBL	Reserved
0X24	TC1CR1	TMRBH	Reserved
0X25	TC1CR2	Reserved	Reserved
0X26	TC1DA	Reserved	Reserved
0X27	TC1DB	Reserved	Reserved
0X28	TC2CR1	Reserved	Reserved
0X29	TC2CR2	Reserved	Reserved
0X2A	TC2DA	Reserved	Reserved
0x2B	TC2DB	Reserved	Reserved
0X2C	TC3CR1	Reserved	Reserved
0X2D	TC3CR2	Reserved	Reserved
0X2E	TC3DA	Reserved	Reserved
0X2F	TC3DB	Reserved	Reserved
0X30	I2CCR1	Reserved	Reserved
0X31	I2CCR2	Reserved	Reserved
0X32	I2CSA	Reserved	Reserved
0X33	I2CDB	Reserved	Reserved
0X34	I2CDAL	Reserved	Reserved
0X35	I2CDAH	Reserved	Reserved
0X36	Reserved	Reserved	Reserved
0X37	Reserved	Reserved	Reserved
0X38	Reserved	Reserved	Reserved
0X39	Reserved	Reserved	Reserved
0X3A	Reserved	Reserved	Reserved
0x3B	Reserved	Reserved	Reserved
0X3C	Reserved	Reserved	Reserved
0X3D	Reserved	Reserved	Reserved
0X3E	ADCR1	Reserved	Reserved
0X3F	Reserved	Reserved	Reserved
0X40	ADISR	WCR	Reserved
0X41	ADER1	Reserved	Reserved
0X42	Reserved	Reserved	Reserved
0X43	ADDL	Reserved	Reserved
0X44	ADDH	FLKR	Reserved
0X45	ADCVL	TBPTL	Reserved

Address	Bank 0	Bank 1	Bank 2
0X46	ADCVH	TBPTH	Reserved
0X47	Reserved	STKMON	LOCKPR
0X48	Reserved	PCH	LOCKCR
0X49	Reserved	LVDCR	Reserved
0X4A	Reserved	Reserved	Reserved
0x4B	Reserved	Reserved	Reserved
0X4C	Reserved	Reserved	Reserved
0X4D	Reserved	TBWCR	Reserved
0X4E	Reserved	TBWAL	Reserved
0X4F	Reserved	TBAWAH	Reserved
0X50	General Purpose Register		
0X51			
.			
.			
0x7E			
0X7F			
0X80			
0X81			
.			
.			
.			
0XFE			
0XFF			

Figure 6-2 Data Memory Configuration

6.1.4 R3: SR (Status Register)

Bit 7	Bit 6	Bit 5	Bit 4	Bit 3	Bit 2	Bit 1	Bit 0
INT	N	OV	T	P	Z	DC	C
F	R/W	R/W	R/W	R/W	R/W	R/W	R/W

Bit 7 (INT): Interrupt Enable flag

0: Interrupt masked by DISI or hardware interrupt

1: Interrupt enabled by ENI/RETI instructions

Bit 6 (N): Negative flag

The negative flag stores the state of the most significant bit of the output result

0: The result of the operation is not negative

1: The result of the operation is negative

Bit 5 (OV): Overflow flag.

OV is set when a two's complement overflow occurs as a result of an operation

0: No overflow occurred

1: Overflow occurred

Bit 4 (T): Time-out bit

Set to 1 with the "SLEP" and "WDTC" commands, or during power up and reset to 0 by WDT time-out.

Bit 3 (P): Power down bit

Set to 1 during power on or by a "WDTC" command and reset to 0 by a "SLEP" command.

Bit 2 (Z): Zero flag.

Set to "1" if the result of an arithmetic or logic operation is zero.

Bit 1 (DC): Auxiliary carry flag

Bit 0 (C): Carry flag

C is set when a carry occurs and cleared when borrow occurs during an arithmetic operation. The Carry Flag bit is set or cleared, depending on the operation that is performed

For ADD, ADC, INC, INCA instruction

0: No carry occurs

1: Carry occurs

For SUB, SUBB, DEC, DECA, NEG instruction

- 0: Borrow occurs
- 1: No borrow occurs

For RLC, RRC, RLCA, RRCA instruction

The Carry flag is used as a link between the least significant bit (LSB) and most significant bit (MSB).

6.1.5 R4: RSR (RAM Select Register)

Bits 7~0 (RSR7~RSR0):used to select registers (Address: 00~FF) in the indirect address mode. Users can see the configuration of the data memory in more detail in Figure 6-2.

Bit 7	Bit 6	Bit 5	Bit 4	Bit 3	Bit 2	Bit 1	Bit 0
RSR7	RSR6	RSR5	RSR4	RSR3	RSR2	RSR1	RSR0
R/W	R/W	R/W	R/W	R/W	R/W	R/W	R/W

6.1.6 Bank 0 R5 ~ RA (Port 5 ~ Port A)

R5, R6, R7, R8, R9 and RA are I/O data registers.

6.1.7 Bank 0 RB IOCR5 (I/O Port 5 Control Register)

- 0: put the relative I/O pin as output
- 1: put the relative I/O pin into high impedance (default)

6.1.8 Bank 0 RC IOCR6 (I/O Port 6 Control Register)

- 0: put the relative I/O pin as output
- 1: put the relative I/O pin into high impedance (default)

6.1.9 Bank 0 RE: OMCR (Operating Mode Control Register)

Bit 7	Bit 6	Bit 5	Bit 4	Bit 3	Bit 2	Bit 1	Bit 0
CPUS	IDLE	-	-	-	RCM2	RCM1	RCM0
R/W	R/W	0	0	0	R/W	R/W	R/W

Bit 7 (CPUS): CPU Oscillator Source Select.

- 0: Fs: sub-oscillator
- 1: Fm: main-oscillator (default)

When CPUS=0, the CPU oscillator select a sub-oscillator and the main oscillator is stopped.

Bit 6 (IDLE): Idle Mode Enable Bit. This bit will decide SLEP instruction which mode to go.

0: "IDLE=0"+SLEP instruction → sleep mode

1: "IDLE=1"+SLEP instruction → idle mode (default)

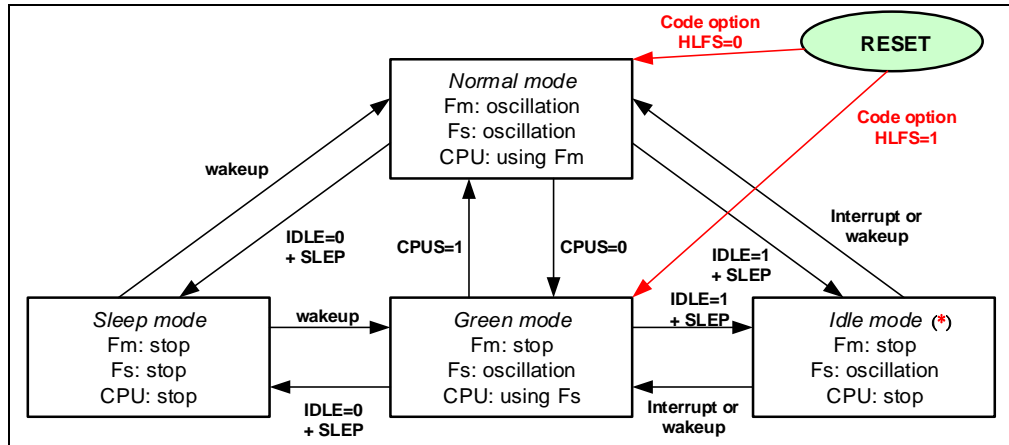

Figure 6-3CPU Operation Mode

Note

(*) Switching Operation Mode from Idle → Normal, Idle → Green

If the clock source of the timer is Fs, the timer/counter will continue to count in Idle mode. When the matching condition of the timer/counter occurs during Idle mode, the interrupt flag of the Timer/Counter will be active. The MCU will jump to the interrupt vector when the corresponding interrupt is enabled.

Oscillation Characteristics
HLFS=0 (Normal)

Fmain	Fsub	Power-on LVR	Pin-Reset / WDT	
			N / G / I	S
RC 4M 6M,8M	RC	16ms + WSTO + (8 or 32)*1/Fmain	WSTO + (8 or 32)*1/Fmain	WSTO + (8 or 32)*1/Fmain
	XT	16ms + WSTO + 510*1/Fsub	WSTO + (8 or 32)*1/Fmain	WSTO + 510*1/Fsub
RC 12M,16M, 20M	RC	16ms + WSTO + 32*1/Fmain	WSTO + 32*1/Fmain	WSTO + 32*1/Fmain
	XT	16ms + WSTO + 510*1/Fsub	WSTO + 32*1/Fmain	WSTO + 510*1/Fsub
XT	RC	16ms + WSTO + 510*1/Fmain	WSTO + 510*1/Fmain	WSTO + 510*1/Fmain
	XT	16ms + WSTO + 510*1/Fsub	WSTO + 510*1/Fmain	WSTO + 510*1/Fsub

HLFS=1 (Green)

Fmain	Fsub	Power-on LVR	Pin-Reset / WDT	
			N/G/I	S
RC 4M, 6M,8M	RC	16ms + WSTO + 8 *1/Fsub	WSTO + 8*1/Fsub	WSTO + 8*1/Fsub
	XT	16ms + WSTO + 510*1/Fsub	WSTO + 8*1/Fsub	WSTO + 510*1/Fsub
RC 12M,16M, 20M	RC	16ms + WSTO + 8*1/Fsub	WSTO + 8*1/Fsub	WSTO + 8*1/Fsub
	XT	16ms + WSTO + 510*1/Fsub	WSTO + 8*1/Fsub	WSTO + 510*1/Fsub
XT	RC	16ms + WSTO + 8*1/Fsub	WSTO + 8*1/Fsub	WSTO + 8*1/Fsub
	XT	16ms + WSTO + 510*1/Fsub	WSTO + 8*1/Fsub	WSTO + 510*1/Fsub

Fmain	Fsub	G → N	I → N	S → N
RC 4M 6M,8M	RC	WSTO + (8 or 32)*1/Fmain	WSTO + (8 or 32)*1/Fmain	WSTO + (8 or 32)*1/Fmain
	XT	WSTO + (8 or 32)*1/Fmain	WSTO + (8 or 32)*1/Fmain	WSTO + 510*1/Fsub
RC 12M,16M, 20M	RC	WSTO + 32*1/Fmain	WSTO + 32*1/Fmain	WSTO + 32*1/Fmain
	XT	WSTO + 32*1/Fmain	WSTO + 32*1/Fmain	WSTO + 510*1/Fsub
XT	RC	WSTO + 510*1/Fmain	WSTO + 510*1/Fmain	WSTO + 510*1/Fmain
	XT	WSTO + 510*1/Fmain	WSTO + 510*1/Fmain	WSTO + 510*1/Fsub

Fmain	Fsub	I → G	S → G
RC	RC	WSTO + 8*1/Fsub	WSTO + 8*1/Fsub
XT	XT	WSTO + 8*1/Fsub	WSTO + 510*1/Fsub

N: Normal mode
WSTO: Waiting Time from Start-to-Oscillation
G: Green mode
I: Idle mode
S: Sleep mode

Bits 5~3: Not used, set to "0" all the time

Bits 2~0 (RCM2~RCM0): Internal RC mode selection bits

RCM2	RCM1	RCM0	Frequency (MHz)
0	0	0	4 (Default)
0	0	1	NA
0	1	0	6
0	1	1	8
1	0	0	12
1	0	1	16
1	1	0	20
1	1	1	NA

6.1.10 Bank 0 RF: EIESCR (External Interrupt Edge Select Control Register)

Bit 7	Bit 6	Bit 5	Bit 4	Bit 3	Bit 2	Bit 1	Bit 0
-	-	-	-	EIES1	EIES0	-	-
0	0	0	0	R/W	R/W	0	0

Bits 7~4: Not used, set to "0" all the time

Bit 3 (EIES1): external interrupt edge select bit

0: Falling edge interrupt

1: Rising edge interrupt

Bit 2 (EIES0): external interrupt edge select bit

0: Falling edge interrupt

1: Rising edge interrupt

Bits 1~0: Not used, set to "0" all the time

6.1.11 Bank 0 R10: WUCR1 (Wake-up Control Register 1)

Bit 7	Bit 6	Bit 5	Bit 4	Bit 3	Bit 2	Bit 1	Bit 0
-	-	LVDWK	ADWK	INT1WK	INT0WK	-	-
0	0	R/W	R/W	R/W	R/W	0	0

Bits 7~6: Not used, set to "0" all the time

Bit 5 (LVDWK): Low Voltage Detect Wake-up Enable Bit

0: Disable Low Voltage Detect wake-up

1: Enable Low Voltage Detect wake-up

Bit 4 (ADWK): A/D Converter Wake-up Function Enable Bit

- 0: Disable AD converter wake-up
- 1: Enable AD converter wake-up

When the AD Complete status is used to enter interrupt vector or to wake-up IC from sleep/idle with AD conversion running, the ADWK bit must be set to “Enable”.

Bit 3 (INT1WK): External Interrupt (INT1 pin)Wake-up Function Enable Bit

- 0: Disable external interrupt wake-up
- 1: Enable external interrupt wake-up

Bit 2 (INT0WK): External Interrupt (INT0 pin)Wake-up Function Enable Bit

- 0: Disable external interrupt wake-up
- 1: Enable external interrupt wake-up

When the External Interrupt status changed is used to enter interrupt vector or to wake-up IC from sleep/idle, the INTWK bits must be set to “Enable”.

Bits 1~0: Not used, set to “0” all the time

6.1.12 Bank 0 R11: WUCR2 (Wake-up Control Register 2)

Bit 7	Bit 6	Bit 5	Bit 4	Bit 3	Bit 2	Bit 1	Bit 0
-	-	-	-	-	I2CWK	-	-
0	0	0	0	0	R/W	0	0

Bits 7~3: Not used, set to “0” all the time.

Bit 2 (I2CWK): I2C wake-up enable bit. It’s available when I2C works at slave mode.

- 0: Disable
- 1: Enable

*I2C slave mode cannot transmit at IC Green mode, or else SCL held and kept at low level. SCL is released when IC switches to Normal mode.

Bits 1~0: Not used, set to “0” all the time.

6.1.13 Bank 0 R12: WUCR3 (Wake-up Control Register 3)

Bit 7	Bit 6	Bit 5	Bit 4	Bit 3	Bit 2	Bit 1	Bit 0
ICWKP8	-	ICWKP6	ICWKP5	-	-	-	-
R/W	0	R/W	R/W	0	0	0	0

Bits 7~4(ICWKP8~ICWKP5): pin change wake up enable for Ports 8/6/5.

0: Disable wake up function

1: Enable wake up function

Bits 3~0: Not used, set to "0" all the time

Wake-up Signal	Condition Signal	Sleep Mode		Idle Mode		Green Mode		Normal Mode	
		DISI	ENI	DISI	ENI	DISI	ENI	DISI	ENI
Pin Change/NT	ICWKP _x = 0, P _x ICIE = 0	Wake-up is invalid				Interrupt is invalid			
	ICWKP _x = 0, P _x ICIE = 1	Wake-up is invalid				Next Instruction	Interrupt + Interrupt Vector	Next Instruction	Interrupt + Interrupt Vector
	ICWKP _x = 1, P _x ICIE = 0	Wake up + Next Instruction				Interrupt is invalid			
	ICWKP _x = 1, P _x ICIE = 1	Wake up + Next Instruction	Wake up + Interrupt Vector	Wake up + Next Instruction	Wake up + Interrupt Vector	Next Instruction	Interrupt + Interrupt Vector	Next Instruction	Interrupt + Interrupt Vector

*: When the MCU wakes up from sleep or idle mode, the P_xICSF must be equal to 1. If ICSF is equal to 0, it means the pin status doesn't change or the pin change ICIE is disabled, hence the MCU cannot be awakened.

** : P_x = Ports 8/6/5

6.1.14 Bank 0 R13: (Reserved)

6.1.15 Bank 0 R14: SFR1 (Status Flag Register 1)

Bit 7	Bit 6	Bit 5	Bit 4	Bit 3	Bit 2	Bit 1	Bit 0
-	-	LVDSF	ADSF	EXSF1	EXSF0	WT SF	TCSF
0	0	F	F	F	F	F	F

Each corresponding status flag is set to "1" when interrupt condition is triggered.

Bits 7~6: Not used, set to "0" all the time

Bit 5 (LVDSF): Low Voltage Detector status flag.

LV DEN	LVDS1, LVDS0	LVD Voltage Interrupt Level	LVDSF
1	11	2.2V	1*
1	10	3.3V	1*
1	01	4.0V	1*
1	00	4.5V	1*
0	xx	NA	0

*If VDD has crossover at the LVD voltage interrupt level as VDD varies, LVDSF =1.

Bit 4 (ADSF): Status flag for analog to digital conversion. Set when AD conversion is completed, reset by software.

Bit 3 (EXSF1): External Interrupt 1 Status flag.

Bit 2 (EXSF0): External Interrupt 0 Status flag.

Bit 1 (WTSF): Watch Timer Status Flag.

Bit 0 (TCSF): TCC Overflow Status Flag. Set when TCC overflows, reset by software.

NOTE

If a function is enabled, the corresponding status flag would be active whether the interrupt mask is enabled or not.

6.1.16 Bank 0 R15: SFR2 (Status Flag Register 2)

Bit 7	Bit 6	Bit 5	Bit 4	Bit 3	Bit 2	Bit 1	Bit 0
-	-	-	-	-	TC3SF	TC2SF	TC1SF
0	0	0	0	0	F	F	F

Each corresponding status flag is set to "1" when interrupt condition is triggered.

Bits 7~3: Not used, set to "0" all the time

Bit 2 (TC3SF): 8-bit Timer/Counter 3 Status Flag, cleared by software

Bit 1 (TC2SF): 8-bit Timer/Counter 2 Status Flag, cleared by software.

Bit 0 (TC1SF): 8/16-bit Timer/Counter 1 Status Flag, cleared by software.

6.1.17 Bank 0 R16: SFR3 (Status Flag Register 3)

Bit 7	Bit 6	Bit 5	Bit 4	Bit 3	Bit 2	Bit 1	Bit 0
-	-	-	-	PWMBPSF	PWMBDSF	PWMAPSF	PWMADSF
0	0	0	0	F	F	F	F

Bits 7~4: Not used, set to "0" all the time

Bit 3 (PWMBPSF): Status flag of period-matching for PWMB (Pulse Width Modulation). Set when reached a selected period, reset by software.

Bit 2 (PWMBDSF): Status flag of duty-matching for PWMB (Pulse Width Modulation). Set when reached a selected duty, reset by software.

Bit 1 (PWMAPSF): Status flag of period-matching for PWMA (Pulse Width Modulation). Set when reached a selected period, reset by software.

Bit 0 (PWMADSF): Status flag of duty-matching for PWMA (Pulse Width Modulation).
Set when reached a selected duty, reset by software.

NOTE

If a function is enabled, the corresponding status flag would be active whether the interrupt mask is enabled or not.

6.1.18 Bank 0 R17: SFR4 (Status Flag Register 4)

Bit 7	Bit 6	Bit 5	Bit 4	Bit 3	Bit 2	Bit 1	Bit 0
P8ICSF	-	P6ICSF	P5ICSF	-	I2CSTPSF	I2CRSF	I2CTSF
F	0	F	F	0	F	F	F

Bit 7 (P8ICSF): Port 8 input status change status flag. Set when Port 8 input changes, reset by software.

Bit 6: Not used, set to "0" all the time.

Bit 5 (P6ICSF): Port 6 input status change status flag. Set when Port 6 input changes, reset by software.

Bit 4 (P5ICSF): Port 5 input status change status flag. Set when Port 5 input changes, reset by software.

Bit 3: Not used, set to "0" all the time.

Bit 2 (I2CSTPSF): I2C stop status flag. Set when I2C receive stop signal.

Bit 1 (I2CRSF): I2C receive status flag. Set when I2C receives 1 byte data and responds to ACK signal. Reset by firmware or I2C disable.

Bit 0 (I2CTSF): I2C transmit status flag. Set when I2C transmits 1-byte data and receives handshake signal (ACK or NACK). Reset by firmware or I2C disable

NOTE

If a function is enabled, the corresponding status flag would be active whether the interrupt mask is enabled or not.

6.1.19 Bank 0 R18: (Reserved)

6.1.20 Bank 0 R19: SFR6 (Status Flag Register 6)

Bit 7	Bit 6	Bit 5	Bit 4	Bit 3	Bit 2	Bit 1	Bit 0
SHSF	-	-	-	-	-	-	-
F	0	0	0	0	0	0	0

Bit 7: (SHSF): System hold status flag, Set when system hold occur, reset by software.

Bits 6~0: Not used, set to "0" all the time

6.1.21 Bank 0 R1A: (Reserved)

6.1.22 Bank 0 R1B: IMR1 (Interrupt Mask Register 1)

Bit 7	Bit 6	Bit 5	Bit 4	Bit 3	Bit 2	Bit 1	Bit 0
-	-	LVDIE	ADIE	EXIE1	EXIE0	WTIE	TCIE
0	0	R/W	R/W	R/W	R/W	R/W	R/W

Bits 7~6: Not used, set to "0" all the time.

Bit 5 (LVDIE): LVDSF interrupt enable bit.

0: Disable LVDSF interrupt

1: Enable LVDSF interrupt

Bit 4 (ADIE): ADSF interrupt enable bit.

0: Disable ADSF interrupt

1: Enable ADSF interrupt.

Bit 3 (EXIE1): EXSF1 interrupt enable and **INT1 function enable bit.**

0: P51/ADC1/INT1 is P51/ADC1pin,
EXSF1 always equal to 0.

1: Enable EXSF1Interrupt and P51/ADC1/INT1 is INT pin

Bit 2 (EXIE0): EXSF0 Interrupt Enable and **INT0 function enable bit.**

0: P50/ADC0/INT0 is P50/ADC0pin,
EXSF0 always equals 0.

1: Enable EXSF0Interrupt and P50/ADC0/INT0 is INT pin

Bit 1 (WTIE): Watch Timer Interrupt Enable bit

0: Disable WTSF interrupt

1: Enable WTSF interrupt

Bit 0 (TCIE): TCSF Interrupt Enable bit.

0: Disable TCSF interrupt

1: Enable TCSF interrupt

NOTE

If the interrupt mask and instruction "ENI" is enabled, the program counter would jump into the corresponding interrupt vector when the corresponding status flag is set.

6.1.23 Bank 0 R1C: IMR2 (Interrupt Mask Register 2)

Bit 7	Bit 6	Bit 5	Bit 4	Bit 3	Bit 2	Bit 1	Bit 0
-	-	-	-	-	TC3IE	TC2IE	TC1IE
0	0	0	0	0	R/W	R/W	R/W

Bits 7~3: Not used, set to "0" all the time.

Bit 2 (TC3IE): Interrupt enable bit.

0: Disable TC3SF interrupt

1: Enable TC3SF interrupt

Bit 1 (TC2IE): Interrupt enable bit.

0: Disable TC2SF interrupt

1: Enable TC2SF interrupt

Bit 0 (TC1IE): Interrupt enable bit.

0: Disable TC1SF interrupt

1: Enable TC1SF interrupt

NOTE

If the interrupt mask and instruction "ENI" is enabled, the program counter would jump into the corresponding interrupt vector when the corresponding status flag is set.

6.1.24 Bank 0 R1D: IMR3 (Interrupt Mask Register 3)

Bit 7	Bit 6	Bit 5	Bit 4	Bit 3	Bit 2	Bit 1	Bit 0
-	-	-	-	PWMBPIE	PWMBDIE	PWMAPIE	PWMADIE
0	0	0	0	R/W	R/W	R/W	R/W

Bits 7~4: Not used, set to "0" all the time.

Bit 3 (PWMBPIE): PWMBPSF interrupt enable bit.

0: Disable period-matching of PWMB interrupt

1: Enable period-matching of PWMB interrupt

Bit 2 (PWMBDIE): PWMBDSF interrupt enable bit.

0: Disable duty-matching of PWMB interrupt

1: Enable duty-matching of PWMB interrupt

Bit 1 (PWMAPIE): PWMAPSF interrupt enable bit.

0: Disable period-matching of PWMA interrupt

1: Enable period-matching of PWMA interrupt

Bit 0 (PWMADIE): PWMADSF interrupt enable bit.

0: Disable duty-matching of PWMA interrupt

1: Enable duty-matching of PWMA interrupt

NOTE

If the interrupt mask and instruction "ENI" is enabled, the program counter would jump into corresponding interrupt vector when the corresponding status flag is set.

6.1.25 Bank 0 R1E: IMR4 (Interrupt Mask Register 4)

Bit 7	Bit 6	Bit 5	Bit 4	Bit 3	Bit 2	Bit 1	Bit 0
P8ICIE	-	P6ICIE	P5ICIE	-	I2CSTPIE	I2CRIE	I2CTIE
R/W	0	R/W	R/W	0	R/W	R/W	R/W

Bit 7 (P8ICIE): P8ICSF interrupt enable bit.

0: Disable P8ICSF interrupt

1: Enable P8ICSF interrupt

Bit 6: Not used, set to "0" all the time.

Bit 5 (P6ICIE): P6ICSF interrupt enable bit.

0: Disable P6ICSF interrupt

1: Enable P6ICSF interrupt

Bit 4 (P5ICIE): P5ICSF interrupt enable bit.

0: Disable P5ICSF interrupt

1: Enable P5ICSF interrupt

Bit 3: Not used, set to "0" all the time.

Bit 2 (I2CSTPIE): I2C stop interrupt enable bit.

0: Disable interrupt

1: Enable interrupt

Bit 1 (I2CRIE): I2C Interface RX interrupt enable bit

0: Disable interrupt

1: Enable interrupt

Bit 0 (I2CTIE): I2C Interface TX interrupt enable bit

0: Disable interrupt

1: Enable interrupt

NOTE

If the interrupt mask and instruction "ENI" is enabled, the program counter would jump into corresponding interrupt vector when the corresponding status flag is set.

6.1.26 Bank 0 R1F: (Reserved)

6.1.27 Bank 0 R20: IMR6 (Interrupt Mask Register 6)

Bit 7	Bit 6	Bit 5	Bit 4	Bit 3	Bit 2	Bit 1	Bit 0
SHIE	-	-	-	-	-	-	-
R/W	0	0	0	0	0	0	0

Bit 7 (SHIE): SHSF Interrupt Enable Bit

0: Disable SHSF interrupt

1: Enable SHSF interrupt

Bits 6~0: Not used, set to "0" all the time.

6.1.28 Bank 0 R21: WDTCR (Watchdog Timer Control Register)

Bit 7	Bit 6	Bit 5	Bit 4	Bit 3	Bit 2	Bit 1	Bit 0
WDTE	-	-	-	PSWE	WPSR2	WPSR1	WPSR0
R/W	0	0	0	R/W	R/W	R/W	R/W

Bit 7 (WDTE): Watchdog Timer Enable Bit. WDTE is both readable and writable.

0: Disable WDT

1: Enable WDT

Bits 6~4: Not used, set to "0" all the time.

Bit 3 (PSWE): Prescaler Enable Bit for WDT

0: Prescaler Disable Bit. WDT rate is 1:1

1: Prescaler Enable Bit. WDT rate is set at Bits 2~0.

Bits 2~0 (WPSR2~WPSR0): WDT Prescaler Bits

WPSR2	WPSR1	WPSR0	WDT Rate
0	0	0	1:2
0	0	1	1:4
0	1	0	1:8
0	1	1	1:16

1	0	0	1:32
1	0	1	1:64
1	1	0	1:128
1	1	1	1:256

6.1.29 Bank 0 R22: TCCCR (TCC Control Register)

Bit 7	Bit 6	Bit 5	Bit 4	Bit 3	Bit 2	Bit 1	Bit 0
-	TCCS	TS	TE	PSTE	TPSR2	TPSR1	TPSR0
0	R/W	R/W	R/W	R/W	R/W	R/W	R/W

Bit 7: Not used, set to “0” all the time.

Bit 6 (TCCS): TCC Clock Source Select Bit

0: Fs (sub clock)

1: Fm (main clock)

Bit 5 (TS): TCC signal source

0: Internal instruction cycle clock

1: Transition on the TCC pin, TCC period must be larger than the internal instruction clock period.

Bit 4 (TE): TCC Signal Edge

0: Increment if the transition from low to high takes place on the TCC pin;

1: Increment if the transition from high to low takes place on the TCC pin

Bit 3 (PSTE): Prescaler enable bit for TCC

0: Prescaler disable bit. TCC rate is 1:1.

1: Prescaler enable bit. TCC rate is set at Bit 2 ~ Bit 0.

Bits 2~0 (TPSR2~TPSR0): TCC Prescaler Bits

TPSR2	TPSR1	TPSR0	TCC Rate
0	0	0	1:2
0	0	1	1:4
0	1	0	1:8
0	1	1	1:16
1	0	0	1:32
1	0	1	1:64
1	1	0	1:128
1	1	1	1:256

6.1.30 Bank 0 R23: TCCD (TCC Data Register)

Bit 7	Bit 6	Bit 5	Bit 4	Bit 3	Bit 2	Bit 1	Bit 0
TCC7	TCC6	TCC5	TCC4	TCC3	TCC2	TCC1	TCC0
R/W	R/W	R/W	R/W	R/W	R/W	R/W	R/W

Bits 7~0 (TCC7~TCC0): TCC data

Increase by an external signal edge through the TCC pin, or by the instruction cycle clock. External signal of TCC trigger pulse width must be greater than one instruction. The signals to increase the counter are determine by Bit 4 and Bit 5 of the TCCCR register. Writable and readable as any other registers.

6.1.31 Bank 0 R24: TC1CR1 (Timer/Counter 1 Control Register 1)

Bit 7	Bit 6	Bit 5	Bit 4	Bit 3	Bit 2	Bit 1	Bit 0
TC1S	TC1RC	TC1SS1	TC1MOD	TC1FF	TC1MOS	TC1IS1	TC1IS0
R/W	R/W	R/W	R/W	R/W	R/W	R/W	R/W

Bit 7 (TC1S): Timer/Counter 1 Start Control Bit

- 0: Stop and clear counter (default)
- 1: Start

Bit 6 (TC1RC): Timer 1 Read Control Bit. To load current number of counter into TC1DB register. It's useful only in counter mode.

- 0: Disable function. When using capture mode, this bit must be set to "0" (default).
- 1: Enable function. The number of counting are loaded into TC1DB.

Bit 5 (TC1SS1): Timer/Counter 1Clock Source Select Bit1

- 0: Internal clock as count source (Fc)- Fs/Fm (default)
- 1: External TC1 pin as count source (Fc). Used only in timer/counter mode.

Bit 4 (TC1MOD): Timer Operation Mode Selection Bit

- 0: Two 8-bit timers
- 1: Timers 1 and 2 are cascaded as one 16-bit timer. The corresponding control register of 16-bit timer is from timer 1. TC2DB and TC2DA are high byte. TC1DB and TC1DA are low bytes.

Bit 3 (TC1FF): Inversion for Timer/Counter 1 as PWM or PDO mode

- 0: Duty is Logic 1 (default)
- 1: Duty is Logic 0

Bit 2 (TC1MOS): Timer Output Mode Select Bit

0: Repeating mode (default)

1: One-shot mode

NOTE

One-shot mode means the timer only counts one cycle.

Bits 1~0 (TC1IS1~ TC1IS0): Timer 1 Interrupt Type Select Bits. These two bits are used when the Timer operates in PWM mode.

TC1IS1	TC1IS0	Timer 1 Interrupt Type Select
0	0	TC1DA(period) matching
0	1	TC1DB(duty) matching
1	x	TC1DA and TC1DB matching

6.1.32 Bank 0 R25: TC1CR2 (Timer/Counter 1 Control Register 2)

Bit 7	Bit 6	Bit 5	Bit 4	Bit 3	Bit 2	Bit 1	Bit 0
TC1M2	TC1M1	TC1M0	TC1SS0	TC1CK3	TC1CK2	TC1CK1	TC1CK0
R/W	R/W	R/W	R/W	R/W	R/W	R/W	R/W

Bits 7~5 (TC1M2~TC1M0): Timer/Counter 1 operation mode select.

TC1M2	TC1M1	TC1M0	Operating Mode Select
0	0	0	Timer/Counter Rising Edge
0	0	1	Timer/Counter Falling Edge
0	1	0	Capture Mode Rising Edge
0	1	1	Capture Mode Falling Edge
1	0	0	Window mode
1	0	1	Programmable Divider output
1	1	0	Pulse Width Modulation output
1	1	1	Buzzer (output timer/counter clock source. The duty cycle of the clock source must be 50/50)

Bit 4 (TC1SS0): Timer/Counter 1 clock source selection bit

0 : The Fs is used as count source (Fc) (default)

1 : The Fm is used as count source (Fc)

Bits 3~0 (TC1CK3~TC1CK0): Timer/Counter 1 clock source prescaler select.

TC1CK3	TC1CK2	TC1CK1	TC1CK0	Clock Source	Resolution 8MHz	Max time 8MHz	Resolution 16kHz	Max. time 16kHz
				Normal	F _C =8M	F _C =8M	F _C =16K	F _C =16K
0	0	0	0	F _C	125ns	32 μs	62.5μs	16ms
0	0	0	1	F _C /2	250ns	64 μs	125μs	32ms
0	0	1	0	F _C /2 ²	500ns	128 μs	250μs	64ms
0	0	1	1	F _C /2 ³	1μs	256 μs	500μs	128ms
0	1	0	0	F _C /2 ⁴	2μs	512 μs	1ms	256ms
0	1	0	1	F _C /2 ⁵	4μs	1024 μs	2ms	512ms
0	1	1	0	F _C /2 ⁶	8μs	2048 μs	4ms	1024ms
0	1	1	1	F _C /2 ⁷	16μs	4096 μs	8ms	2048ms
1	0	0	0	F _C /2 ⁸	32μs	8192 μs	16ms	4096ms
1	0	0	1	F _C /2 ⁹	64μs	16384 μs	32ms	8192ms
1	0	1	0	F _C /2 ¹⁰	128μs	32768 μs	64ms	16384ms
1	0	1	1	F _C /2 ¹¹	256μs	65536 μs	128ms	32768ms
1	1	0	0	F _C /2 ¹²	512μs	131072 μs	256ms	65536ms
1	1	0	1	F _C /2 ¹³	1.024ms	262144 μs	512ms	131072ms
1	1	1	0	F _C /2 ¹⁴	2.048ms	524.288ms	1.024s	262144ms
1	1	1	1	F _C /2 ¹⁵	4.096ms	1.048s	2.048s	524288ms

6.1.33 Bank 0 R26: TC1DA (Timer/Counter 1 Data Buffer A)

Bit 7	Bit 6	Bit 5	Bit 4	Bit 3	Bit 2	Bit 1	Bit 0
TC1DA7	TC1DA6	TC1DA5	TC1DA4	TC1DA3	TC1DA2	TC1DA1	TC1DA0
R/W	R/W	R/W	R/W	R/W	R/W	R/W	R/W

Bits 7~0 (TC1DA7~TC1DA0): Data Buffer A of 8-bit Timer/Counter 1

6.1.34 Bank 0 R27: TC1DB (Timer/Counter 1 Data Buffer B)

Bit 7	Bit 6	Bit 5	Bit 4	Bit 3	Bit 2	Bit 1	Bit 0
TC1DB7	TC1DB6	TC1DB5	TC1DB4	TC1DB3	TC1DB2	TC1DB1	TC1DB0
R/W	R/W	R/W	R/W	R/W	R/W	R/W	R/W

Bits 7~0 (TC1DB7~TC1DB0): Data Buffer B of 8 bit Timer/Counter 1

NOTE

1. When Timer / Counter x is used as PWM mode, the duty value stored at register TCxDB must be smaller than or equal to the period value stored at register TCxDA., i.e. $duty \leq period$. And then the PWM waveform is generated. If the duty is larger than the period, the PWM output waveform is kept at **high** voltage level.
2. The period value set by users is extra plus 1 in inner circuit.
 For example:
 The period value is set as 0x4F, the circuit actually processes 0x50 period length.
 The period value is set as 0xFF, the circuit actually processes 0x100 period length.

6.1.35 Bank 0 R28: TC2CR1 (Timer/Counter 2 Control Register 1)

Bit 7	Bit 6	Bit 5	Bit 4	Bit 3	Bit 2	Bit 1	Bit 0
TC2S	TC2RC	TC2SS1	–	TC2FF	TC2MOS	TC2IS1	TC2IS0
R/W	R/W	R/W	–	R/W	R/W	R/W	R/W

Bit 7 (TC2S): Timer/Counter 2 Start Control Bit

0: Stop and clear counter (default)

1: Start

Bit 6 (TC2RC): Timer 2 Read Control Bit

0: When this bit is set to 0, cannot read data from TC2DB (default).

1: When this bit is set to 1, data read from TC2DB is a number of counting.

Bit 5 (TC2SS1): Timer/Counter 2 clock source select Bit1

0: Internal clock as count source (Fc)- Fs/Fm (default)

1: External TC2 pin as count source (Fc). It is used only for timer/counter mode.

Bit 4: Not used, set to "0" all the time.

Bit 3 (TC2FF): Inversion for Timer/Counter 2 as PWM or PDO mode

0: Duty is Logic 1 (default)

1: Duty is Logic 0

Bit 2 (TC2MOS): Timer Output Mode Select Bit

0: Repeating mode (default)

1: One-shot mode

NOTE

One-shot mode means the timer only counts one cycle.

Bits 1~0 (TC2IS1~ TC2IS0): Timer 2 Interrupt Type Select Bits. These two bits are used when the Timer operates in PWM mode.

TC2IS1	TC2IS0	Timer 2 Interrupt Type Select
0	0	TC2DA(period) matching
0	1	TC2DB(duty) matching
1	x	TC2DA and TC2DB matching

6.1.36 Bank 0 R29: TC2CR2 (Timer/Counter 2 Control Register 2)

Bit 7	Bit 6	Bit 5	Bit 4	Bit 3	Bit 2	Bit 1	Bit 0
TC2M2	TC2M1	TC2M0	TC2SS0	TC2CK3	TC2CK2	TC2CK1	TC2CK0
R/W	R/W	R/W	R/W	R/W	R/W	R/W	R/W

Bits 7~5 (TC2M2~TC2M0): Timer/Counter 2 operation mode select.

TC2M2	TC2M1	TC2M0	Operating Mode Select
0	0	0	Timer/Counter Rising Edge
0	0	1	Timer/Counter Falling Edge
0	1	0	Capture Mode Rising Edge
0	1	1	Capture Mode Falling Edge
1	0	0	Window mode
1	0	1	Programmable Divider output
1	1	0	Pulse Width Modulation output
1	1	1	Buzzer (output timer/counter clock source. The duty cycle of the clock source must be 50/50)

Bit 4 (TC2SS0): Timer/Counter 2clock source select Bit0

0: The Fs is used as count source (Fc) (default)

1: The Fm is used as count source (Fc)

Bits 3~0 (TC2CK3~TC2CK0): Timer/Counter 2 clock source prescaler select.

TC2CK3	TC2CK2	TC2CK1	TC2CK0	Clock Source	Resolution 8 MHz	Max. time 8MHz	Resolution 16kHz	Max time 16kHz
				Normal	F _C =8M	F _C =8M	F _C =16K	F _C =16K
0	0	0	0	F _C	125ns	32μs	62.5μs	16ms
0	0	0	1	F _C /2	250ns	64μs	125μs	32ms
0	0	1	0	F _C /2 ²	500ns	128μs	250μs	64ms
0	0	1	1	F _C /2 ³	1μs	256μs	500μs	128ms
0	1	0	0	F _C /2 ⁴	2μs	512μs	1ms	256ms
0	1	0	1	F _C /2 ⁵	4μs	1024μs	2ms	512ms
0	1	1	0	F _C /2 ⁶	8μs	2048μs	4ms	1024ms
0	1	1	1	F _C /2 ⁷	16μs	4096μs	8ms	2048ms
1	0	0	0	F _C /2 ⁸	32μs	8192μs	16ms	4096ms
1	0	0	1	F _C /2 ⁹	64μs	16384μs	32ms	8192ms
1	0	1	0	F _C /2 ¹⁰	128μs	32768μs	64ms	16384ms
1	0	1	1	F _C /2 ¹¹	256μs	65536μs	128ms	32768ms
1	1	0	0	F _C /2 ¹²	512μs	131072μs	256ms	65536ms
1	1	0	1	F _C /2 ¹³	1.024ms	262144μs	512ms	131072ms
1	1	1	0	F _C /2 ¹⁴	2.048ms	524.288ms	1.024s	262144ms
1	1	1	1	F _C /2 ¹⁵	4.096ms	1.048s	2.048s	524288ms

6.1.37 Bank 0 R2A: TC2DA (Timer/Counter 2 Data Buffer A)

Bit 7	Bit 6	Bit 5	Bit 4	Bit 3	Bit 2	Bit 1	Bit 0
TC2DA7	TC2DA6	TC2DA5	TC2DA4	TC2DA3	TC2DA2	TC2DA1	TC2DA0
R/W	R/W	R/W	R/W	R/W	R/W	R/W	R/W

Bits 7~0 (TC2DA7~TC2DA0): Data Buffer A of the 8 bit Timer/Counter 2.

6.1.38 Bank 0 R2B: TC2DB (Timer/Counter 2 Data Buffer B)

Bit 7	Bit 6	Bit 5	Bit 4	Bit 3	Bit 2	Bit 1	Bit 0
TC2DB7	TC2DB6	TC2DB5	TC2DB4	TC2DB3	TC2DB2	TC2DB1	TC2DB0
R/W	R/W	R/W	R/W	R/W	R/W	R/W	R/W

Bits 7~0 (TC2DB7~TC2DB0): Data Buffer B of the 8 bit Timer/Counter 2

6.1.39 Bank 0 R2C: TC3CR1 (Timer/Counter 3 Control Register 1)

Bit 7	Bit 6	Bit 5	Bit 4	Bit 3	Bit 2	Bit 1	Bit 0
TC3S	TC3RC	TC3SS1	-	TC3FF	TC3MOS	TC3IS1	TC3IS0
R/W	R/W	R/W	0	R/W	R/W	R/W	R/W

Bit 7 (TC3S): Timer/Counter 3 start control

0: Stop and clear counter (default)

1: Start

Bit 6 (TC3RC): Timer 3 Read Control Bit

0: When this bit is set to 0, cannot read data from TC3DB (default).

1: When this bit is set to 1, data read from TC3DB is a number of counting.

Bit 5 (TC3SS1): Timer/Counter 3 clock source select Bit1

0: Internal clock as count source (Fc)- Fs/Fm (default)

1: External TC3 pin as count source (Fc). Used only in timer/counter mode.

Bit 4: Not used, set to "0" all the time.

Bit 3 (TC3FF): Inversion for Timer/Counter 3 as PWM or PDO mode.

0: Duty is Logic 1 (default)

1: Duty is Logic 0.

Bit 2 (TC3MOS): Timer Output Mode Select Bit

0: Repeating mode (default)

1: One-shot mode

NOTE

One-shot mode means the timer only counts a circle.

Bits 1~0 (TC3IS1~ TC3IS0): Timer 3 Interrupt Type Select Bits. These two bits are used when the Timer operates in PWM mode.

TC3IS1	TC3IS0	Timer 3 Interrupt Type Select
0	0	TC3DA (period) matching
0	1	TC3DB (duty) matching
1	x	TC3DA and TC3DB matching

6.1.40 Bank 0 R2D: TC3CR2 (Timer/Counter 3 Control Register 2)

Bit 7	Bit 6	Bit 5	Bit 4	Bit 3	Bit 2	Bit 1	Bit 0
TC3M2	TC3M1	TC3M0	TC3SS0	TC3CK3	TC3CK2	TC3CK1	TC3CK0
R/W	R/W	R/W	R/W	R/W	R/W	R/W	R/W

Bits 7~5 (TC3M2~TC3M0): Timer/Counter 3 operation mode select.

TC3M2	TC3M1	TC3M0	Operating Mode Select
0	0	0	Timer/Counter Rising Edge
0	0	1	Timer/Counter Falling Edge
0	1	0	Capture Mode Rising Edge
0	1	1	Capture Mode Falling Edge
1	0	0	Window mode
1	0	1	Programmable Divider output
1	1	0	Pulse Width Modulation output
1	1	1	Buzzer (output timer/counter clock source. The duty cycle of the clock source must be 50/50)

Bit 4 (TC3SS0): Timer/Counter 3 clock source select Bit 0

0: The Fs is used as count source (Fc) (default)

1: The Fm is used as count source (Fc)

Bits 3~0 (TC3CK3~TC3CK0): Timer/Counter 3 clock source prescaler select.

TC3CK3	TC3CK2	TC3CK1	TC3CK0	Clock Source	Resolution 8 MHz	Max. time 8 MHz	Resolution 16kHz	Max. time 16kHz
				Normal	F _c =8M	F _c =8M	F _c =16K	F _c =16K
0	0	0	0	F _c	125ns	32 μs	62.5 μs	16ms
0	0	0	1	F _c /2	250ns	64 μs	125 μs	32ms
0	0	1	0	F _c /2 ²	500ns	128 μs	250 μs	64ms
0	0	1	1	F _c /2 ³	1 μs	256 μs	500 μs	128ms
0	1	0	0	F _c /2 ⁴	2 μs	512 μs	1ms	256ms
0	1	0	1	F _c /2 ⁵	4 μs	1024 μs	2ms	512ms
0	1	1	0	F _c /2 ⁶	8 μs	2048 μs	4ms	1024ms
0	1	1	1	F _c /2 ⁷	16 μs	4096 μs	8ms	2048ms
1	0	0	0	F _c /2 ⁸	32 μs	8192 μs	16ms	4096ms
1	0	0	1	F _c /2 ⁹	64 μs	16384 μs	32ms	8192ms
1	0	1	0	F _c /2 ¹⁰	128 μs	32768 μs	64ms	16384ms
1	0	1	1	F _c /2 ¹¹	256 μs	65536 μs	128ms	32768ms
1	1	0	0	F _c /2 ¹²	512 μs	131072 μs	256ms	65536ms
1	1	0	1	F _c /2 ¹³	1.024ms	262144 μs	512ms	131072ms
1	1	1	0	F _c /2 ¹⁴	2.048ms	524.288ms	1.024s	262144ms
1	1	1	1	F _c /2 ¹⁵	4.096ms	1.048s	2.048s	524288ms

6.1.41 Bank 0 R2E: TC3DA (Timer/Counter 3 Data Buffer A)

Bit 7	Bit 6	Bit 5	Bit 4	Bit 3	Bit 2	Bit 1	Bit 0
TC3DA7	TC3DA6	TC3DA5	TC3DA4	TC3DA3	TC3DA2	TC3DA1	TC3DA0
R/W	R/W	R/W	R/W	R/W	R/W	R/W	R/W

Bits 7~0 (TC3DA7~TC3DA0): Data Buffer A of 8-bit Timer/Counter 3

6.1.42 Bank 0 R2F: TC3DB (Timer/Counter 3 Data Buffer B)

Bit 7	Bit 6	Bit 5	Bit 4	Bit 3	Bit 2	Bit 1	Bit 0
TC3DB7	TC3DB6	TC3DB5	TC3DB4	TC3DB3	TC3DB2	TC3DB1	TC3DB0
R/W	R/W	R/W	R/W	R/W	R/W	R/W	R/W

Bits 7~0 (TC3DB7~TC3DB0): Data Buffer B of 8-bit Timer/Counter 3

6.1.43 Bank 0 R30: I2CCR1 (I2C Status and Control Register 1)

Bit 7	Bit 6	Bit 5	Bit 4	Bit 3	Bit 2	Bit 1	Bit 0
Strobe/Pend	IMS	ISS	STOP	SAR_EMPTY	ACK	FULL	EMPTY
R/W	R/W	R/W	R/W	R	R	R	R

Bit 7 (Strobe/Pend): In master mode, it is used as strobe signal to control I2C circuit to send SCL clock. Reset automatically after receiving or transmitting handshake signal (ACK or NACK). In slave mode, it is used as pending signal, user should clear it after filling data into Tx buffer or obtaining data from Rx buffer to inform slave I2C circuit to release SCL signal.

Bit 6 (IMS): I2C Master/Slave mode select bit.

0: Slave (Default)

1: Master

Bit 5 (ISS): I2C Fast/Standard mode select bit. (If Fm is 4 MHz and I2CTS2~0<0,0,1>)

0: Standard mode (100K bit/s)

1: Fast mode (400K bit/s)

Bit 4 (STOP): In Master mode, if STOP=1 and R/nW=1 then MCU must return nACK signal to slave device before send STOP signal. If STOP=1 and R/nW=0 then MCU send STOP signal after receive an ACK signal. Reset when MCU send STOP signal to Slave device. In slave mode, if STOP=1 and R/nW=0 then MCU must return nACK signal to master device.

Bit 3 (SAR_EMPTY): Set when MCU transmit 1 byte data from I2C Slave Address Register and receive ACK (or nACK) signal. Reset when MCU write 1 byte data to I2C Slave Address Register.

Bit 2 (ACK): The ACK condition bit is set to 1 by hardware when the device responds acknowledge (ACK). Reset when the device responds not-acknowledge (nACK) signal

Bit 1 (FULL): Set by hardware when I2C receive buffer register is full. Reset by hardware when MCU read data from I2C receive buffer register.

Bit 0 (EMPTY): Set by hardware when I2C transmit buffer register is empty and receive ACK (or nACK) signal. Reset by hardware when MCU write new data to I2C transmit buffer register.

6.1.44 Bank 0 R31: I2CCR2 (I2C Status and Control Register 2)

Bit 7	Bit 6	Bit 5	Bit 4	Bit 3	Bit 2	Bit 1	Bit 0
I2CBF	GCEN	I2COPT	BBF	I2CTS2	I2CTS1	I2CTS0	I2CEN
R	R/W	R/W	R	R/W	R/W	R/W	R/W

Bit 7 (I2CBF): I2C Busy Flag Bit

0: Clear to "0", in Slave mode, if receive STOP signal or I2C slave address not match.

1: Set when I2C communicate with master in slave mode.

*Set when STAR signal, clear when I2C disable or STOP signal for Slave mode.

Bit 6 (GCEN): I2C General Call Function Enable Bit

0: Disable General Call Function

1: Enable General Call Function

Bit 5 (I2COPT): I2C pin optional bit. It is use to switch the pin position of the I2C function.

0: Placed I2C pins in P62 (SDA0) and P82 (SCL0) (default)

1: Placed I2C pins in P84 (SDA1) and P83 (SCL1).

*Default value corresponding code option Word 2 I2COPT

Bit 4 (BBF): Busy Flag Bit. I2C detection is busy in the master mode. Read only.

*Set when STAR signal, clear when STOP signal for Master mode.

Bits 3~1 (I2CTS2~I2CTS0): I2C Transmit Clock Select Bits. When using different operating frequency (Fm), these bits must be set correctly to let SCL clock fill-in with standard/fast mode.

I2CCR1 Bit 5=1, Fast Mode

I2CTS2	I2CTS1	I2CTS0	SCL CLK	Operating Fm (MHz)
0	0	0	NA	NA
0	0	1	Fm/10	4
0	1	0	Fm/15	6
0	1	1	Fm/20	8
1	0	0	Fm/30	12
1	0	1	Fm/40	16
1	1	0	Fm/50	20
1	1	1	NA	NA

I2CCR1 Bit5=0, Standard Mode

I2CTS2	I2CTS1	I2CTS0	SCL CLK	Operating Fm (MHz)
0	0	0	Fm/10	1
0	0	1	Fm/40	4
0	1	0	Fm/60	6
0	1	1	Fm/80	8
1	0	0	Fm/120	12
1	0	1	Fm/160	16
1	1	0	Fm/200	20
1	1	1	NA	NA

Bit 0 (I2CEN): I2C Enable Bit

0: Disable I2C mode (Default)

1: Enable I2C mode

6.1.45 Bank 0 R32: I2CSA (I2C Slave Address Register)

Bit 7	Bit 6	Bit 5	Bit 4	Bit 3	Bit 2	Bit 1	Bit 0
SA6	SA5	SA4	SA3	SA2	SA1	SA0	IRW
R/W	R/W	R/W	R/W	R/W	R/W	R/W	R/W

Bits 7~1 (SA6~SA0): When MCU used as master device for I2C application. This is the slave device address register.

Bit 0 (IRW): When MCU used as master device for I2C application. This bit is Read/Write transaction control bit.

0: Write

1: Read

6.1.46 Bank 0 R33: I2CDB (I2C Data Buffer Register)

Bit 7	Bit 6	Bit 5	Bit 4	Bit 3	Bit 2	Bit 1	Bit 0
DB7	DB6	DB5	DB4	DB3	DB2	DB1	DB0
R/W	R/W	R/W	R/W	R/W	R/W	R/W	R/W

Bits 7~0 (DB7~DB0): I2C Receive/Transmit Data Buffer.

6.1.47 Bank 0 R34: I2CDAL (I2C Device Address Register)

Bit 7	Bit 6	Bit 5	Bit 4	Bit 3	Bit 2	Bit 1	Bit 0
DA7	DA6	DA5	DA4	DA3	DA2	DA1	DA0
R/W	R/W	R/W	R/W	R/W	R/W	R/W	R/W

Bits 7~0 (DA7~DA0): When MCU used as slave device for I2C application, this register store the address of MCU. It is use to identify the data on the I2C bus to extract the message delivered to the MCU.

6.1.48 Bank 0 R35: I2CDAH (I2C Device Address Register)

Bit 7	Bit 6	Bit 5	Bit 4	Bit 3	Bit 2	Bit 1	Bit 0
-	-	-	-	-	-	DA9	DA8
0	0	0	0	0	0	R/W	R/W

Bits 7~2: Not used bits, set to "0" all the time.

Bits 1~0 (DA9~DA8): Device Address Bits.

6.1.49 Bank 0 R36 ~R3D: (Reserved)
6.1.50 Bank 0 R3E: ADCR1 (ADC Control Register 1)

Bit 7	Bit 6	Bit 5	Bit 4	Bit 3	Bit 2	Bit 1	Bit 0
CKR2	CKR1	CKR0	ADRUN	ADP	ADOM	SHS1	SHS0
R/W	R/W	R/W	R/W	R/W	R/W	R/W	R/W

Bits7~5 (CKR2~0): Clock Rate Selection of ADC

System Mode	CKR2~0	Clock Rate	Max. System Operation Frequency in 2.1~2.2V	Max. System Operation Frequency in 2.2~2.7V	Max. System Operation Frequency in 2.7~5V
Normal Mode	000	FMain/16	8 MHz	16 MHz	20 MHz
	001	FMain/8	4 MHz	8 MHz	16 MHz
	010	FMain/4	2 MHz	4 MHz	8 MHz
	011	FMain/2	1 MHz	2 MHz	4 MHz
	100	FMain/64	20 MHz	20 MHz	20 MHz
	101	FMain/32	16 MHz	20 MHz	20 MHz
	110	FMain/1	500 kHz	1 MHz	2 MHz
	111	FSub	Fs	Fs	Fs
Green Mode	xxx	FSub	Fs	Fs	Fs

Bit 4 (ADRUN): ADC Starts to Run

In single mode:

- 0: Reset on completion of the conversion by hardware, this bit cannot be reset by software.
- 1: A/D conversion starts. This bit can be set by software

In continuous mode:

- 0: ADC is stopped.
- 1: ADC is running unless this bit is reset by software

Bit 3 (ADP): ADC Power

- 0: ADC is in power down mode.
- 1: ADC is operating normally.

Bit 2 (ADOM): ADC Operation Mode Selection

- 0: ADC operates in single mode.
- 1: ADC operates in continuous mode.

Bits 1~0 (SHS1~0): Sample and Hold Timing Selection

SHS[1:0]	Sample and Hold Timing
00	2 x T _{AD}
01	4 x T _{AD}
10	8 x T _{AD}
11	12 x T _{AD}

6.1.51 Bank 0 R3F: ADCR2 (ADC Control Register 2)

Bit 7	Bit 6	Bit 5	Bit 4	Bit 3	Bit 2	Bit 1	Bit 0
-	VPIS2	ADIM	ADCMS	VPIS1	VPIS0	VREFP	-
0	R/W	R/W	R/W	R/W	R/W	R/W	0

Bit 7: Not used, set to "0" all the time.

Bit 5 (ADIM): ADC Interrupt Mode

0: Normal mode. Interrupt occurred after AD conversion completed.

1: Compare mode. Interrupt occurred when comparison result conforms the setting of ADCMS bits.

Bit 4 (ADCMS): ADC Comparison Mode Selection.

In compare mode:

0: Interrupt occurred when AD conversion data is greater than data in ADCD register.

It means when $ADD > ADCD$, interrupt occurred.

1: Interrupt occurred when AD conversion data is less than data in ADCD register.

It means when $ADD < ADCD$, interrupt occurred.

In normal mode:

No effect

Bits 6, 3 ~ 2 (VPIS2~0): Internal Positive Reference Voltage Selection.

VPIS[2]	VPIS[1:0]	Reference Voltage
0	00	AVDD
0	01	4 V
0	10	3 V
0	11	2 V
1	11	2.5 V

Bit 1 (VREFP): Positive Reference Voltage Selection

0: Internal positive reference voltage. The actual voltage is set by VPIS[1:0] bits

1: From VREF pin.

Bit 0: Not used, set to "0" all the time.

NOTE

When using internal voltage reference and the code option Word 2<7> is set to "0", users need to wait 50μs at least the first time to enable and stabilize the internal voltage reference circuit. After that, users only need to wait 6us at least whenever switching voltage references.

6.1.52 Bank 0 R40: ADISR (Analog to Digital Converter Input Channel Selection Register)

Bit 7	Bit 6	Bit 5	Bit 4	Bit 3	Bit 2	Bit 1	Bit 0
-	-	-	-	ADIS3	ADIS2	ADIS1	ADIS0
0	0	0	0	R/W	R/W	R/W	R/W

Bits 7~4: Not used, set to "0" all the time.

Bits 3~0 (ADIS3~0): ADC input channel selection bits

ADIS[3:0]	Selected Channel
0000	ADC0
0001	ADC1
0010	ADC2
0011	ADC3
0100	ADC4
0101	ADC5
0110	ADC6
0111	ADC7
1xxx*	1/2 VDD PowerDet.

Note:

*: For internal signal source use. Users only need to set ADIS3=1, these AD input channels are instantly active, internal VrefStable Time is 4 μ s.

6.1.53 Bank 0 R41: ADER1 (Analog to Digital Converter Input Control Register 1)

Bit 7	Bit 6	Bit 5	Bit 4	Bit 3	Bit 2	Bit 1	Bit 0
ADE7	ADE6	ADE5	ADE4	ADE3	ADE2	ADE1	ADE0
R/W	R/W	R/W	R/W	R/W	R/W	R/W	R/W

Bit 7 (ADE7): AD converter enable bit of P57 pin.

- 0: Disable ADC7, P57/PWMB/ADC7 act as I/O or PWMB pin
- 1: Enable ADC7 act as analog input pin.

Bit 6 (ADE6): AD converter enable bit of P56 pin.

- 0: Disable ADC6, P56/PWMA/ADC act as I/O or PWMA pin
- 1: Enable ADC6 act as analog input pin

Bit 5 (ADE5): AD converter enable bit of P55 pin.

- 0: Disable ADC5, P55/ADC5 act as I/O pin
- 1: Enable ADC5 act as analog input pin

Bit 4 (ADE4): AD converter enable bit of P54 pin.

- 0: Disable ADC4, P54/ADC4 act as I/O pin
- 1: Enable ADC4 act as analog input pin

Bit 3 (ADE3): AD converter enable bit of P53 pin.

- 0: Disable ADC3, P53/ADC3 act as I/O pin
- 1: Enable ADC3 act as analog input pin

Bit 2 (ADE2): AD converter enable bit of P52 pin.

- 0: Disable ADC2, P52/ADC2/TCC act as I/O or TCC pin
- 1: Enable ADC2 act as analog input pin

Bit 1 (ADE1): AD converter enable bit of P51 pin.

- 0: Disable ADC1, P51/ADC1/INT1 act as I/O or /INT1 pin
- 1: Enable ADC1 act as analog input pin

Bit 0 (ADE0): AD converter enable bit of P50 pin.

- 0: Disable ADC0, P50/ADC0/INT0 act as I/O or /INT0 pin
- 1: Enable ADC0 act as analog input pin

6.1.54 Bank 0 R42: (Reserved)

6.1.55 Bank 0 R43: ADDL (Low Byte of Analog to Digital Converter Data)

Bit 7	Bit 6	Bit 5	Bit 4	Bit 3	Bit 2	Bit 1	Bit 0
ADD7	ADD6	ADD5	ADD4	ADD3	ADD2	ADD1	ADD0
R	R	R	R	R	R	R	R

Bits 7~0 (ADD7~0): Low Byte of AD Data Buffer

6.1.56 Bank 0 R44: ADDH (High Byte of Analog to Digital Converter Data)

Bit 7	Bit 6	Bit 5	Bit 4	Bit 3	Bit 2	Bit 1	Bit 0
ADD15	ADD14	ADD13	ADD12	ADD11	ADD10	ADD9	ADD8
R	R	R	R	R	R	R	R

Bits 7~0 (ADD15~8): High Byte of AD Data Buffer.

The format of AD data is dependent on the Code Option ADFM. The following table shows how the data justified in different ADFM setting.

ADFM		Bit 7	Bit 6	Bit 5	Bit 4	Bit 3	Bit 2	Bit 1	Bit 0	
12 bits	0	ADDH					ADD11	ADD10	ADD9	ADD8
		ADDL	ADD7	ADD6	ADD5	ADD4	ADD3	ADD2	ADD1	ADD0
	1	ADDH	ADD11	ADD10	ADD9	ADD8	ADD7	ADD6	ADD5	ADD4
		ADDL					ADD3	ADD2	ADD1	ADD0

6.1.57 Bank 0 R45 ADCVL (Low Byte of Analog to Digital Converter Comparison)

Bit 7	Bit 6	Bit 5	Bit 4	Bit 3	Bit 2	Bit 1	Bit 0
ADCD7	ADCD6	ADCD5	ADCD4	ADCD3	ADCD2	ADCD1	ADCD0
R/W	R/W	R/W	R/W	R/W	R/W	R/W	R/W

Bits 7~0 (ADCD7~0): Low Byte Data for AD Comparison.

User should use the data format as the same as ADDH and ADDL register. Otherwise, a faulty result will be obtained after AD comparison.

6.1.58 Bank 0 R46 ADCVH (High Byte of Analog to Digital Converter Comparison)

Bit 7	Bit 6	Bit 5	Bit 4	Bit 3	Bit 2	Bit 1	Bit 0
ADCD15	ADCD14	ADCD13	ADCD12	ADCD11	ADCD10	ADCD9	ADCD8
R/W	R/W	R/W	R/W	R/W	R/W	R/W	R/W

Bits 7~0 (ADCD15~8): High Byte Data for AD Comparison

User should use the data format the same as ADDH and ADDL register. Otherwise, a faulty result will be obtained after AD comparison.

6.1.59 Bank 0 R47 ~ R4F(Reserved)

6.1.60 Bank 1 R5 IOCR8 (I/O Port 8 Control Register)

0: put the relative I/O pin as output

1: put the relative I/O pin into high impedance (default)

6.1.61 Bank 1 R6 ~ R7 (Reserved)

6.1.62 Bank 1 R8: P5PHCR (Port 5 Pull-high Control Register)

Bit 7	Bit 6	Bit 5	Bit 4	Bit 3	Bit 2	Bit 1	Bit 0
PH57	PH56	PH55	PH54	PH53	PH52	PH51	PH50
R/W	R/W	R/W	R/W	R/W	R/W	R/W	R/W

Bit 7 (PH57): Control bit used to enable pull-high of the P57 pin

0: Enable internal pull-high

1: Disable internal pull-high (default)

Bit 6 (PH56): Control bit used to enable pull-high of the P56 pin

Bit 5 (PH55): Control bit used to enable pull-high of the P55 pin

Bit 4 (PH54): Control bit used to enable pull-high of the P54 pin

Bit 3 (PH53): Control bit used to enable pull-high of the P53 pin

Bit 2 (PH52): Control bit used to enable pull-high of the P52 pin

Bit 1 (PH51): Control bit used to enable pull-high of the P51 pin

Bit 0 (PH50): Control bit used to enable pull-high of the P50 pin

NOTE

If P50, P51 act as external interrupt, the pull-high function will automatically be disabled, and the corresponding control bit will be invalid.

6.1.63 Bank 1 R9: P6PHCR (Port 6 Pull-high Control Register)

Bit 7	Bit 6	Bit 5	Bit 4	Bit 3	Bit 2	Bit 1	Bit 0
-	-	-	PH64	PH63	PH62	PH61	PH60
0	0	0	R/W	R/W	R/W	R/W	R/W

Bits7~5: Not used, set to "0" all the time

Bit 4 (PH64): Control bit used to enable pull-high of the P64 pin

0: Enable internal pull-high

1: Disable internal pull-high (default)

Bit 3 (PH63): Control bit used to enable pull-high of the P63 pin

Bit 2 (PH62): Control bit used to enable pull-high of the P62 pin

Bit 1 (PH61): Control bit used to enable pull-high of the P61 pin

Bit 0 (PH60): Control bit used to enable pull-high of the P60 pin

6.1.64 Bank 1 RA: P8PHCR (Port 8 Pull-high Control Register)

Bit 7	Bit 6	Bit 5	Bit 4	Bit 3	Bit 2	Bit 1	Bit 0
-	-	-	-	P8HPH	P8LPH	-	-
0	0	0	0	R/W	R/W	0	0

Bits 7~4: Not used, set to "0" all the time.

Bit 3 (P8HPH): Control bit used to enable pull-high of the Port8highnibble pin

0: Enable internal pull-high

1: Disable internal pull-high (default)

Bit 2 (P8LPH): Control bit used to enable the pull high of Port8 low nibble pin

Bits 1~0: Not used, set to "0" all the time.

6.1.65 Bank 1 RB: P5PLCR (Port 5 Pull-low Control Register)

Bit 7	Bit 6	Bit 5	Bit 4	Bit 3	Bit 2	Bit 1	Bit 0
PL57	PL56	PL55	PL54	PL53	PL52	PL51	PL50
R/W	R/W	R/W	R/W	R/W	R/W	R/W	R/W

Bit 7 (PL57): Control bit used to enable pull low of the P57 pin

0: Enable internal pull-low

1: Disable internal pull-low (default)

Bit 6 (PL56): Control bit used to enable pull low of the P56 pin

Bit 5 (PL55): Control bit used to enable pull low of the P55 pin

Bit 4 (PL54): Control bit used to enable pull low of the P54 pin

Bit 3 (PL53): Control bit used to enable pull low of the P53 pin

Bit 2 (PL52): Control bit used to enable pull low of the P52 pin

Bit 1 (PL51): Control bit used to enable pull low of the P51 pin

Bit 0 (PL50): Control bit used to enable pull low of the P50 pin

NOTE

If P50, P51 act as external interrupt, the pull-low function will automatically be disabled, and the corresponding control bit will be invalid.

6.1.66 Bank 1 RC: P6PLCR (Port 6 Pull-low Control Register)

Bit 7	Bit 6	Bit 5	Bit 4	Bit 3	Bit 2	Bit 1	Bit 0
-	-	-	PL64	PL63	PL62	PL61	PL60
0	0	0	R/W	R/W	R/W	R/W	R/W

Bits 7~5: Not used, set to "0" all the time.

Bit 4 (PL64): Control bit used to enable pull low of the P64 pin

0: Enable internal pull-low

1: Disable internal pull-low (default)

Bit 3 (PL63): Control bit used to enable pull low of the P63 pin

Bit 2 (PL62): Control bit used to enable pull low of the P62 pin

Bit 1 (PL61): Control bit used to enable pull low of the P61 pin

Bit 0 (PL60): Control bit used to enable pull low of the P60 pin

6.1.67 Bank 1 RD: P8PLCR (Ports8 Pull-low Control Register)

Bit 7	Bit 6	Bit 5	Bit 4	Bit 3	Bit 2	Bit 1	Bit 0
-	-	-	-	P8HPL	P8LPL	-	-
0	0	0	0	R/W	R/W	0	0

Bits 7~4: Not used, set to "0" all the time.

Bit 3 (P8HPL): Control bit used to enable pull low of the Port8 high nibble pin

0: Enable internal pull-low

1: Disable internal pull-low (default)

Bit 2 (P8LPL): Control bit used to enable pull low of the Port 8 low nibble pin

Bits1~0: Not used, set to "0" all the time.

6.1.68 Bank 1 RE: P5HDSCR (Port 5 High Drive/Sink Control Register)

Bit 7	Bit 6	Bit 5	Bit 4	Bit 3	Bit 2	Bit 1	Bit 0
H57	H56	H55	H54	H53	H52	H51	H50
R/W	R/W	R/W	R/W	R/W	R/W	R/W	R/W

Bits 7~0 (H57~H50): P57~P50 high drive/sink current control bits

0: Enable high drive/sink

1: Disable high drive/sink (default)

6.1.69 Bank 1 RF: P6HDSCR (Port 6 High Drive/Sink Control Register)

Bit 7	Bit 6	Bit 5	Bit 4	Bit 3	Bit 2	Bit 1	Bit 0
-	-	-	H64	H63	H62	H61	H60
0	0	0	R/W	R/W	R/W	R/W	R/W

Bits 7~5: Not used, set to "0" all the time.

Bits 4~0 (H64~H60): P64~P60 high drive/sink current control bits

0: Enable high drive/sink

1: Disable high drive/sink (default)

6.1.70 Bank 1 R10: P8HDSCR (Port 8 High Drive/Sink Control Register)

Bit 7	Bit 6	Bit 5	Bit 4	Bit 3	Bit 2	Bit 1	Bit 0
-	-	-	-	P8HHDS	P8LHDS	-	-
0	0	0	0	R/W	R/W	0	0

Bits 7~4: Not used, set to "0" all the time.

Bit 3 (P8HHDS): Control bit used to enable high drive/sink of Port 8 high nibble pin

0: Enable high drive/sink

1: Disable high drive/sink (default)

Bit 2 (P8LHDS): Control bit used to enable high drive/sink of Port 8 low nibble pin

Bits 1~0: Not used, set to "0" all the time.

6.1.71 Bank 1 R11: P5ODCR (Port 5 Open-Drain Control Register)

Bit 7	Bit 6	Bit 5	Bit 4	Bit 3	Bit 2	Bit 1	Bit 0
OD57	OD56	OD55	OD54	OD53	OD52	OD51	OD50
R/W	R/W	R/W	R/W	R/W	R/W	R/W	R/W

Bits 7~0 (OD57~OD50): Open-Drain control bits

0: Disable open-drain function (default)

1: Enable open-drain function

6.1.72 Bank 1 R12: P6ODCR (Port 6 Open-Drain Control Register)

Bit 7	Bit 6	Bit 5	Bit 4	Bit 3	Bit 2	Bit 1	Bit 0
-	-	-	OD64	OD63	OD62	OD61	OD60
0	0	0	R/W	R/W	R/W	R/W	R/W

Bits 7~5: Not used, set to "0" all the time.

Bits 4~0 (OD64~OD60): Open-Drain control bits

0: Disable open-drain function (default)

1: Enable open-drain function

6.1.73 Bank 1 R13: P8ODCR (Port 8 Open-Drain Control Register)

Bit 7	Bit 6	Bit 5	Bit 4	Bit 3	Bit 2	Bit 1	Bit 0
-	-	-	-	P8HOD	P8LOD	-	-
0	0	0	0	R/W	R/W	0	0

Bits 7~4: Not used, set to "0" all the time.

Bit 3 (P8HOD): Control bit used to enable open-drain of Port 8 high nibble pin

0: Disable open-drain function (default)

1: Enable open-drain function

Bit 2 (P8LOD): Control bit used to enable open-drain of Port 8 low nibble pin

Bits 1~0: Not used, set to "0" all the time.

6.1.74 Bank 1 R14: DeadTCR (Dead Time Control Register)

Bit 7	Bit 6	Bit 5	Bit 4	Bit 3	Bit 2	Bit 1	Bit 0
-	-	-	-	DEADTBE	DEADTAE	DEADTP1	DEADTP0
0	0	0	0	R/W	R/W	R/W	R/W

Bits 7~4: Not used, set to "0" all the time

Bit 3 (DEADTBE): Enable dead-time function for PWMB and /PWMB (for dual PWM)

0: Disable (default)

1: Enable

Bit 2 (DEADTAE): Enable dead-time function for PWMA and /PWMA (for dual PWM)

0: Disable (default)

1: Enable

Bits 1~0 (DEADTP1~DEADTP0): Dead-time prescaler

DEADTP1	DEADTP0	Prescaler
0	0	1:1 (default)
0	1	1:2
1	0	1:4
1	1	1:8

NOTE

The deadtime function is only for dual PWM. If using a single PWM function (not dual PWM), the deadtime function is always disabled.

6.1.75 Bank 1 R15: DeadTR (Dead Time Register)

Bit 7	Bit 6	Bit 5	Bit 4	Bit 3	Bit 2	Bit 1	Bit 0
DEADTR7	DEADTR6	DEADTR5	DEADTR4	DEADTR3	DEADTR2	DEADTR1	DEADTR0
R/W	R/W	R/W	R/W	R/W	R/W	R/W	R/W

Bits 7~0 (DEADTR7~0): The contents of the register are dead-time

6.1.76 Bank 1 R16: PWMSCR (PWM Source Clock Control Register)

Bit 7	Bit 6	Bit 5	Bit 4	Bit 3	Bit 2	Bit 1	Bit 0
-	-	-	DEADS	-	-	PWMBS	PWMAS
0	0	0	R/W	0	0	R/W	R/W

Bits 7~5: Not used, set to "0" all the time.

Bit 4 (DEADS): Clock selection for dead time timer

0: Fs (default)

1: Fm

Bits 3~2: Not used, set to "0" all the time.

Bit 1 (PWMBS): Clock selection for PWMB timer

0: Fs (default)

1: Fm

Bit 0 (PWMAS): Clock selection for PWMA timer

0: Fs (default)

1: Fm

6.1.77 Bank 1 R17: PWMACR (PWMA Control Register)

Bit 7	Bit 6	Bit 5	Bit 4	Bit 3	Bit 2	Bit 1	Bit 0
PWMAE	IPWMAE	PWMAA	IPWMAA	TAEN	TAP2	TAP1	TAP0
R/W	R/W	R/W	R/W	R/W	R/W	R/W	R/W

Bit 7 (PWMAE): PWMA enable bit

0: Disable (default)

1: Enable. The compound pin is used as PWMA pin

Bit 6 (IPWMAE): Inverse PWMA enable bit

- 0: Disable (default)
- 1: Enable. The compound pin is used as /PWMA pin

Bit 5 (PWMAA): Active level of PWMA

- 0: Duty -deadtime is Logic 1 (default)
- 1: Duty -deadtime is Logic 0

Bit 4 (IPWMAA): active level of inverse PWMA

- 0: Period-duty-deadtime is Logic 1 (default)
- 1: Period-duty-deadtime is Logic 0

Bit 3 (TAEN): TMRA enable bit. All PWM functions are valid only as this bit is set

- 0 = TMRA is off (default)
- 1 = TMRA is on

PWMxE	TxEN	Function Description
0	0	Not used as PWM function; I/O pin or other function pin.
0	1	Timer function; I/O pin or other function pin.
1	0	PWM function, the waveform keeps at inactive level.
1	1	PWM function, the normal PWM output waveform.

*x = A,B

Bits 2~0 (TAP2~TAP0): TMRA clock prescaler option bits

TAP2	TAP1	TAP0	Prescaler
0	0	0	1:1 (default)
0	0	1	1:2
0	1	0	1:4
0	1	1	1:8
1	0	0	1:16
1	0	1	1:64
1	1	0	1:128
1	1	1	1:256

6.1.78 Bank 1 R18: PRDAL (Low Byte of PWMA Period)

Bit 7	Bit 6	Bit 5	Bit 4	Bit 3	Bit 2	Bit 1	Bit 0
PRDA7	PRDA6	PRDA5	PRDA4	PRDA3	PRDA2	PRDA1	PRDA0
R/W	R/W	R/W	R/W	R/W	R/W	R/W	R/W

Bits 7~0 (PRDA7~PRDA 0): The contents of the register are low byte of the PWMA period.

NOTE

The PWMA duty/period will reload when updating PRDAL register .

6.1.79 Bank 1 R19: PRDAH (High Byte of PWMA Period)

Bit 7	Bit 6	Bit 5	Bit 4	Bit 3	Bit 2	Bit 1	Bit 0
-	-	-	-	-	-	PRDA9	PRDA8
0	0	0	0	0	0	R/W	R/W

Bits 7~0 (PRDA9~PRDA 8): The contents of the register are high byte of PWMA period

6.1.80 Bank 1 R1A: DTAL (Low Byte of PMWA Duty)

Bit 7	Bit 6	Bit 5	Bit 4	Bit 3	Bit 2	Bit 1	Bit 0
DTA7	DTA6	DTA5	DTA4	DTA3	DTA2	DTA1	DTA0
R/W	R/W	R/W	R/W	R/W	R/W	R/W	R/W

Bits 7~0 (DTA7~DTA0): The contents of the register are low byte of the PWMA duty

6.1.81 Bank 1 R1B: DTAH (High Byte of PMWA Duty)

Bit 7	Bit 6	Bit 5	Bit 4	Bit 3	Bit 2	Bit 1	Bit 0
-	-	-	-	-	-	DTA9	DTA8
0	0	0	0	0	0	R/W	R/W

Bits 7~0 (DTA9~DTA 8): The contents of the register are high byte of the PWMA duty

6.1.82 Bank 1 R1C: TMRAL (Low Byte of TimerA)

Bit 7	Bit 6	Bit 5	Bit 4	Bit 3	Bit 2	Bit 1	Bit 0
TMRA7	TMRA6	TMRA5	TMRA4	TMRA3	TMRA2	TMRA1	TMRA0
R	R	R	R	R	R	R	R

Bits 7~0 (TMRA7~TMRA 0): The contents of the register are low byte of the PWMA timer which is counting. This is read-only.

6.1.83 Bank 1 R1D: TMR AH (High byte of Timer A)

Bit 7	Bit 6	Bit 5	Bit 4	Bit 3	Bit 2	Bit 1	Bit 0
-	-	-	-	-	-	TMRA9	TMRA8
0	0	0	0	0	0	R	R

Bits 7~0 (TMRA9~TMRA 8): The contents of the register are high byte of the PWMA timer which is counting. This is read-only.

6.1.84 Bank 1 R1E: PWMB CR (PWMB Control Register)

Bit 7	Bit 6	Bit 5	Bit 4	Bit 3	Bit 2	Bit 1	Bit 0
PWMBE	IPWMBE	PWMBA	IPWMBA	TBEN	TBP2	TBP1	TBP0
R/W	R/W	R/W	R/W	R/W	R/W	R/W	R/W

Bit 7 (PWMBE): PWMB enable bit

0: Disable (default)

1: Enable. The compound pin is used as PWMB pin

Bit 6 (IPWMBE): Inverse PWMB enable bit

0: Disable (default)

1: Enable. The compound pin is used as /PWMB pin

Bit 5 (PWMBA): Active level of PWMB

0: Duty is Logic 1 (default)

1: Duty is Logic 0

Bit 4 (IPWMB): Active level of inverse PWMB

0: period-duty is Logic 1 (default)

1: period-duty is Logic 0

Bit 3 (TBEN): TMRB enable bit. All PWM functions are valid only as this bit is set

0: TMRB is off (default)

1: TMRB is on

Bits 2~0 (TBP2~TBP0): TMRB clock prescaler option bits

TBP2	TBP1	TBP0	Prescaler
0	0	0	1:1 (default)
0	0	1	1:2
0	1	0	1:4
0	1	1	1:8
1	0	0	1:16
1	0	1	1:64
1	1	0	1:128
1	1	1	1:256

6.1.85 Bank 1 R1F: PRDBL (Low Byte of PWMB Period)

Bit 7	Bit 6	Bit 5	Bit 4	Bit 3	Bit 2	Bit 1	Bit 0
PRDB7	PRDB6	PRDB5	PRDB4	PRDB3	PRDB2	PRDB1	PRDB0
R/W	R/W	R/W	R/W	R/W	R/W	R/W	R/W

Bits 7~0 (PRDB7~PRDB 0): The contents of the register are low bytes of the PWMB period.

NOTE

The PWMA duty/period will reload when updating PRDAL register.

6.1.86 Bank 1 R20: PRDBH (High Byte of PWMB period)

Bit 7	Bit 6	Bit 5	Bit 4	Bit 3	Bit 2	Bit 1	Bit 0
-	-	-	-	-	-	PRDB9	PRDB8
0	0	0	0	0	0	R/W	R/W

Bits 7~0 (PRDB9~PRDB 8): The contents of the register are high bytes of PWMB period.

6.1.87 Bank 1 R21: DTBL (Low Byte of PMWB Duty)

Bit 7	Bit 6	Bit 5	Bit 4	Bit 3	Bit 2	Bit 1	Bit 0
DTB7	DTB6	DTB5	DTB4	DTB3	DTB2	DTB1	DTB0
R/W	R/W	R/W	R/W	R/W	R/W	R/W	R/W

Bits 7~0 (DTB7~DTB 0): The contents of the register are low byte of the PMWB duty

6.1.88 Bank 1 R22: DTBH (High Byte of PMWB Duty)

Bit 7	Bit 6	Bit 5	Bit 4	Bit 3	Bit 2	Bit 1	Bit 0
-	-	-	-	-	-	DTB9	DTB8
0	0	0	0	0	0	R/W	R/W

Bits 7~0 (DTB9~DTB 8): The contents of the register are high byte of the PMWB duty

NOTE

The value in the dead-time register must be less than the value in the duty cycle register in order to prevent unexpected behavior on both of the PWM outputs.

6.1.89 Bank1 R23: TMRBL (Low Byte of Timer B)

Bit 7	Bit 6	Bit 5	Bit 4	Bit 3	Bit 2	Bit 1	Bit 0
TMRB7	TMRB6	TMRB5	TMRB4	TMRB3	TMRB2	TMRB1	TMRB0
R	R	R	R	R	R	R	R

Bits 7~0 (TMRB7~TMRB 0): The contents of the register are low byte of the PMWB timer which is counting. This is read-only.

6.1.90 Bank 1 R24: TMRBH (High Byte of Timer B)

Bit 7	Bit 6	Bit 5	Bit 4	Bit 3	Bit 2	Bit 1	Bit 0
-	-	-	-	-	-	TMRB9	TMRB8
0	0	0	0	0	0	R	R

Bits 7~0 (TMRB9~TMRB 8): The contents of the register are high byte of the PMWB timer which is counting. This is read-only

6.1.91 Bank 1 R25 ~ R39: (Reserved)

6.1.92 Bank 1 R40: WCR (Watch Timer Control Register)

Bit 7	Bit 6	Bit 5	Bit 4	Bit 3	Bit 2	Bit 1	Bit 0
WTE	WTSSB1	WTSSB0	-	-	-	-	-
R/W	R/W	R/W	0	0	0	0	0

Bit 7 (WTE): Watch Timer Enable Bit

0: Disable

1: Enable

Bits 6~5 (WTSSB1~WTSSB0): Watch Timer Interval Select Bits

WTSSB1	WTSSB0	Timer Interval Select	Timer Interval Select (LXT3 = 32.768kHz)
0	0	32768 / Fs	1.0s
0	1	16384 / Fs	0.5s
1	0	8192 / Fs	0.25s
1	1	128 / Fs	3.91ms

Note: The clock source of the watch timer comes from the sub-IRC or crystal 32.768kHz.

Bits 4~0: unused bit, set to 0 all the time

6.1.93 Bank1 R41~R43: (Reserved)

6.1.94 Bank 1 R44: FLKR (Flash Key Register for Table Write Use)

Bit 7	Bit 6	Bit 5	Bit 4	Bit 3	Bit 2	Bit 1	Bit 0
FLK[7]	FLK[6]	FLK[5]	FLK[4]	FLK[3]	FLK[2]	FLK[1]	FLK[0]
R/W	R/W	R/W	R/W	R/W	R/W	R/W	R/W

This FLKR register is used by table write IAP mode operation. The IAP enable signal is generated when a specific value is written into this register, e.g., **0xB4**. The register is designed to make sure that IAP operation occurs for flash update.

6.1.95 Bank 1 R45: TBPTL (Table Point Low Register)

Bit 7	Bit 6	Bit 5	Bit 4	Bit 3	Bit 2	Bit 1	Bit 0
TB7	TB6	TB5	TB4	TB3	TB2	TB1	TB0
R/W	R/W	R/W	R/W	R/W	R/W	R/W	R/W

Bits 7~0 (TB7~TB0): Table Point Address Bits 7~0.

6.1.96 Bank 1 R46: TBPTH (Table Point High Register)

Bit 7	Bit 6	Bit 5	Bit 4	Bit 3	Bit 2	Bit 1	Bit 0
HLB	RDS	-	-	-	TB10	TB9	TB8
R/W	R/W	0	0	0	R/W	R/W	R/W

Bit 7 (HLB): Take high byte or low byte content of Flash ROM addressed by TBPTH and TBPTL

RDS	HLB	Read to Register Data Value Description
0	0	Read low byte.
0	1	Read high byte.

Bit 6 (RDS): ROM data select bit, read machine code information select.

0: ROM data (Must be 0 all the time)

Bits 5~3: unused bit, set to 0 all the time

Bits 2 ~0 (TB10~TB8): Table Point Address Bits 10~8.

6.1.97 Bank 1 R47: STKMON (Stack Point)

Bit 7	Bit 6	Bit 5	Bit 4	Bit 3	Bit 2	Bit 1	Bit 0
STOV	-	-	-	STL3	STL2	STL1	STL0
R	0	0	0	R	R	R	R

Bit 7 (STOV): Stack pointer overflow indication bit. Only read.

Bits3~0 (STL3~STL 0): Stack pointer number. Only read.

6.1.98 Bank 1 R48: PCH (Program Counter High)

Bit 7	Bit 6	Bit 5	Bit 4	Bit 3	Bit 2	Bit 1	Bit 0
-	-	-	-	-	PC10	PC9	PC8
0	0	0	0	0	R/W	R/W	R/W

Bits 7~3: Not used, set to "0" all the time.

Bits 2~0 (PC10~PC8): The high byte of program counter.

6.1.99 Bank 1 R49: LVDCR (Low Voltage Detector Control Register)

Bit 7	Bit 6	Bit 5	Bit 4	Bit 3	Bit 2	Bit 1	Bit 0
LVDEN	-	LVDS1	LVDS0	LVDB	-	-	-
R/W	0	R/W	R/W	R	0	0	0

Bit 7 (LVDEN): Low Voltage Detector Enable Bit

0: Disable low voltage detector

1: Enable low voltage detector

Bits 5~4 (LVDS1~LVDS0): Low Voltage Detector Level Bits.

LVDEN	LVDS1, LVDS0	LVD Voltage Interrupt Level	LVDB
1	11	VDD < 2.2V	0
		VDD > 2.4V	1
1	10	VDD < 3.3V	0
		VDD > 3.5V	1
1	01	VDD < 4.0V	0
		VDD > 4.2V	1
1	00	VDD < 4.5V	0
		VDD > 4.7V	1
0	XX	NA	1

Bit 3 (LVDB): Low Voltage Detector State Bit. This is a read only bit. When the VDD pin voltage is lower than LVD voltage interrupt level (selected by LVDS1 ~ LVDS0), this bit will be cleared.

0: The low voltage is detected.

1: The low voltage is not detected or LVD function is disabled.

Bits 6, 2~0: Not used, set to "0" all the time.

6.1.100 Bank 1 R4D TBWCR (Table Write Control Register)

Bit 7	Bit 6	Bit 5	Bit 4	Bit 3	Bit 2	Bit 1	Bit 0
-	-	-	-	-	-	-	IAPEN
0	0	0	0	0	0	0	R/W

Bits 7~1: Not used bits, fixed to "0" all the time.

Bit 0 (IAPEN): IAP enable bit

0: IAP mode Disable

1: IAP mode Enable

6.1.101 Bank 1 R4E: 0cL (Table Write Start Address Low Byte)

Bit 7	Bit 6	Bit 5	Bit 4	Bit 3	Bit 2	Bit 1	Bit 0
TBWA[7]	TBWA[6]	TBWA[5]	TBWA[4]	TBWA[3]	TBWA[2]	TBWA[1]	TBWA[0]
R/W	R/W	R/W	R/W	R/W	R/W	R/W	R/W

Bits7~0 (TBWA[7]~TBWA[0]): Table Write Star Address Bits 7~0, TBWA[4]~TBWA[0] always fixed to "0".

6.1.102 Bank 1 R4F: TBWAH (Table Write Start Address High Byte)

Bit 7	Bit 6	Bit 5	Bit 4	Bit 3	Bit 2	Bit 1	Bit 0
-	-	-	-	-	TBWA[10]	TBWA[9]	TBWA[8]
0	0	0	0	0	R/W	R/W	R/W

Bits 7~3: Fixed to "0" all the time (Read only)

Bits 2~0 (TBWA[10]~TBWA[8]): Table Write Address Bits 12~8.

※**Note :**

ROM Code Buffer (Start)	Table Write ROM Address (Destination)
BANK1 0x80	[TBWA] Low byte (Bits 7~0)
BANK1 0x81	[TBWA] High byte (Bits 15~8)
BANK1 0x82	[TBWA+1] Low byte (Bits 7~0)
BANK1 0x83	[TBWA+1] High byte (Bits 15~8)
⋮	⋮
BANK1 0XBE	[TBWA+31] Low byte (Bits 7~0)
BANK1 0XBF	[TBWA+31] High byte (Bits 15~8)

6.1.103 Bank 2 R5 ~ R46 (Reserved)

6.1.104 Bank 2 R47 LOCKPR (Lock Page Number Register)

Bit 7	Bit 6	Bit 5	Bit 4	Bit 3	Bit 2	Bit 1	Bit 0
LOCKPR7	LOCKPR6	LOCKPR5	LOCKPR4	LOCKPR3	LOCKPR2	LOCKPR1	LOCKPR0
R/W	R/W	R/W	R/W	R/W	R/W	R/W	R/W

Bits 7~0 (LOCKPR7~ LOCKPR0): Lock Page Number

6.1.105 Bank 2 R48 LOCKCR (Lock Control Register)

Bit 7	Bit 6	Bit 5	Bit 4	Bit 3	Bit 2	Bit 1	Bit 0
LOCKEN	-	-	-	-	-	-	-
R/W	0	0	0	0	0	0	0

Bit 7 (LOCKEN): Enhanced Protect Control Bit

0: Disable (Default)

1: Enable

Bits 6~0: Not used, set to "0" all the time.

6.1.106 R50~R7F, Banks 0~3 R80~RFF

All of these are 8-bit general-purpose registers.

6.2 TCC/WDT and Prescaler

There are two 8-bit counters available as prescalers for the TCC and WDT respectively. The TPSR0~TPSR2 bits of the TCCCR register are used to determine the ratio of the prescaler of TCC. Likewise, the WPSR0~WPSR2 bits of the WDTCR register are used to determine the prescaler of WDT. The prescaler counter will be cleared by the instructions each time they are written into TCC. The WDT and prescaler will be cleared by the “WDTC” and “SLEP” instructions.

Figure 6-4 depicts the circuit diagram of TCC/WDT.

TCCD (6.1.30Bank 0 R23) is an 8-bit timer/counter. The clock source of TCC can be internal clock or external signal input (edge selectable from the TCC pin). If TCC signal source is from internal clock, TCC will increase by 1 at every instruction cycle (without prescaler). If TCC signal source is from external clock input, TCC will increase by 1 at every falling edge or rising edge of the TCC pin. TCC pin input time length (keep in High or low level) must greater than 1CLK.

If TCC signal source is from internal clock, the TCC will stop running when sleep mode occurs.

If TCC signal source is from external clock, TCC will increase by 1 at every falling edge or rising edge of the TCC pin when sleep mode occurs.

The watchdog timer is a free running on-chip RC oscillator. The WDT will keep on running even after the oscillator driver has been turned off (i.e. in sleep mode). During the normal operation or the sleep mode, a WDT time-out (if enabled) will cause the device to reset. The WDT can be enabled or disabled at any time during normal mode by software programming. Refer to WDTE bit of WDTCR (6.1.28Bank 0 R21) register. With no prescaler, the WDT time-out period is approximately 16.5ms¹ (one oscillator start-up timer period).

¹**Note:** VDD=5V, WDT time-out period = 16.5ms ± 5%.
VDD=3V, WDT time-out period = 16.5ms ± 5%.

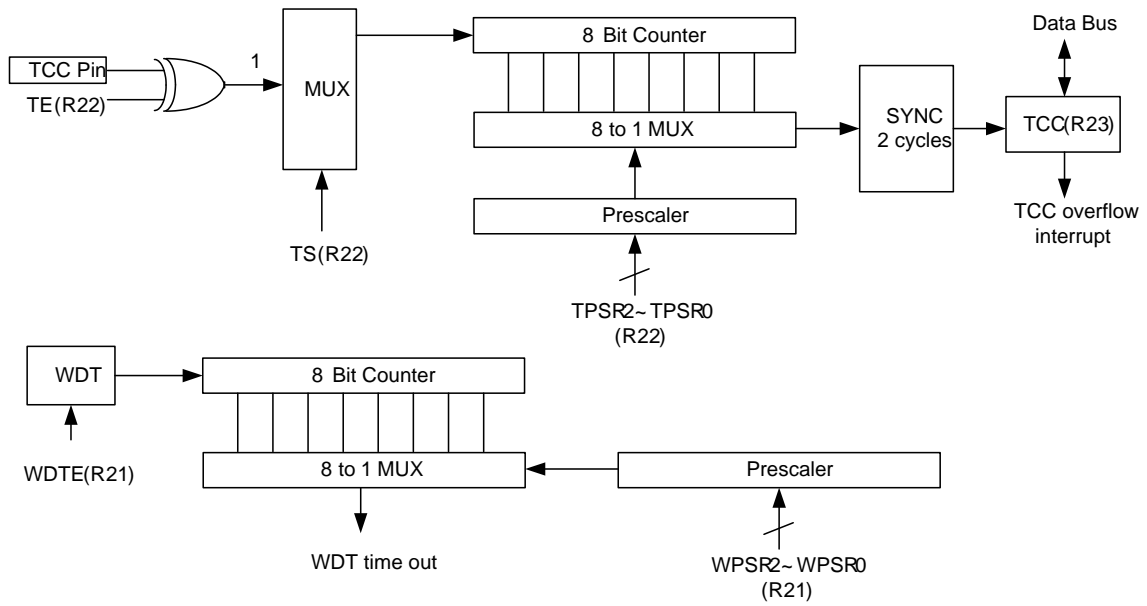
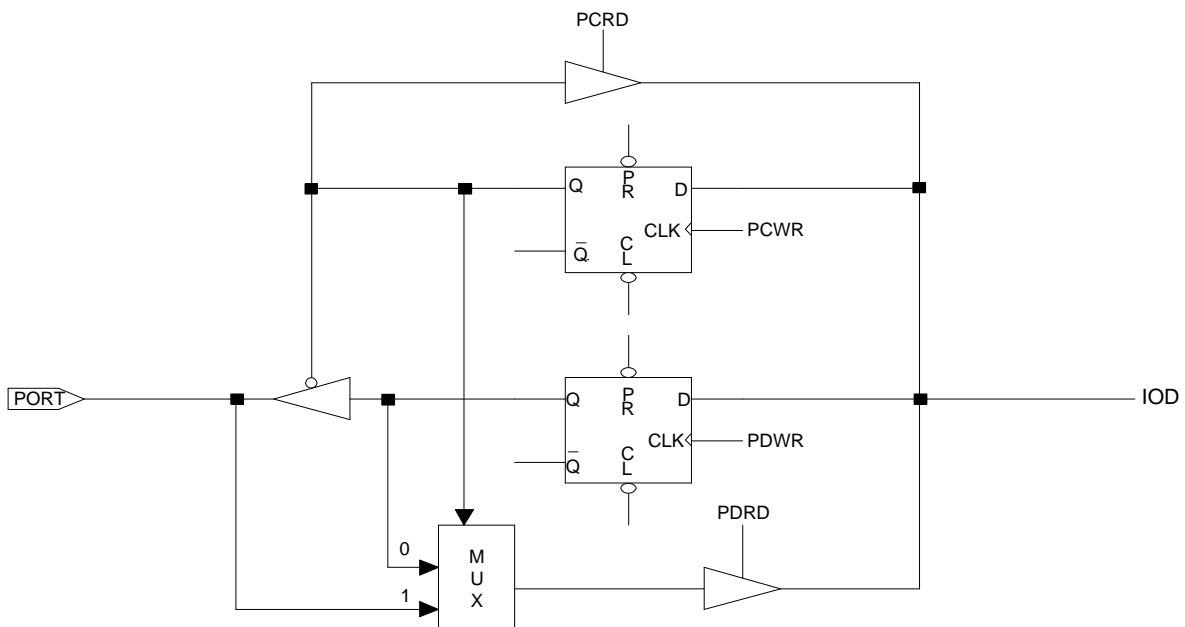

Figure 6-4 Block Diagram of TCC and WDT

6.3 I/O Ports

The I/O registers, Port 5~Port 8 are bi-directional tri-state I/O ports. All of them can be pulled high or low internally by software. In addition, they can also have open-drain output and high sink/drive setting by software. Ports 5~8 have wake up and interrupt function. Further, Ports5~8 also have input status change interrupt function. Each I/O pin can be defined as "input" or "output" pin by the I/O control register (IOCR5 ~ IOCR8).

The I/O registers and I/O control registers are both readable and writable. The I/O interface circuits for Port 5 ~ Port 8 are shown in the following Figure 6-5, Figure 6-6, Figure 6-7, and Figure 6-8.



Note: Pull-down is not shown in the figure.

Figure 6-5 Circuit of I/O Port and I/O Control Register for Ports5~8

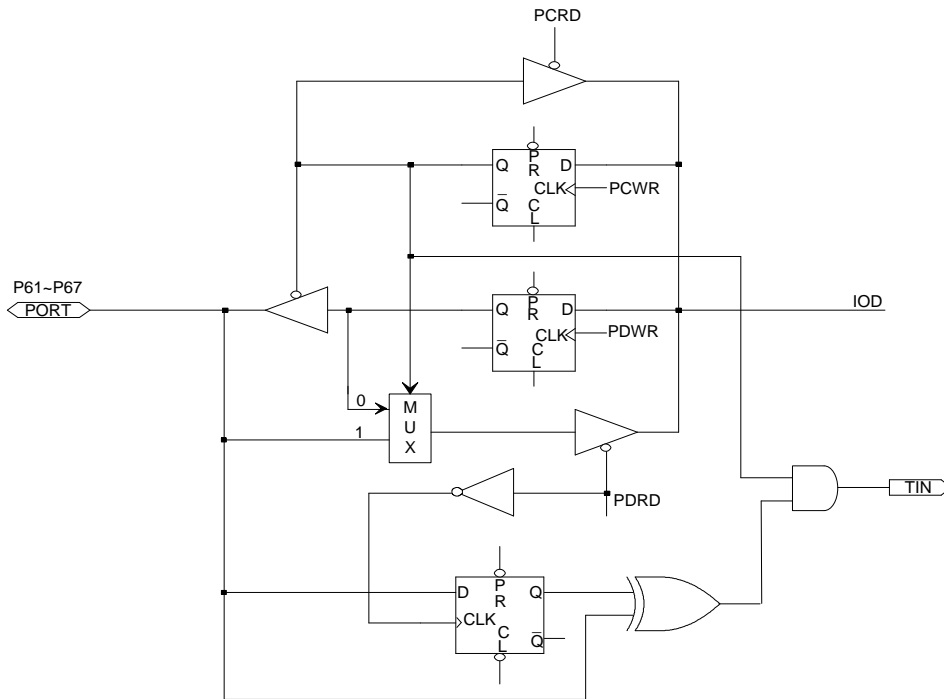

Note: Pull-high (down) and Open-drain are not shown in the figure.

Figure 6-7 Circuit of I/O Port and I/O Control Register for Port 5-8

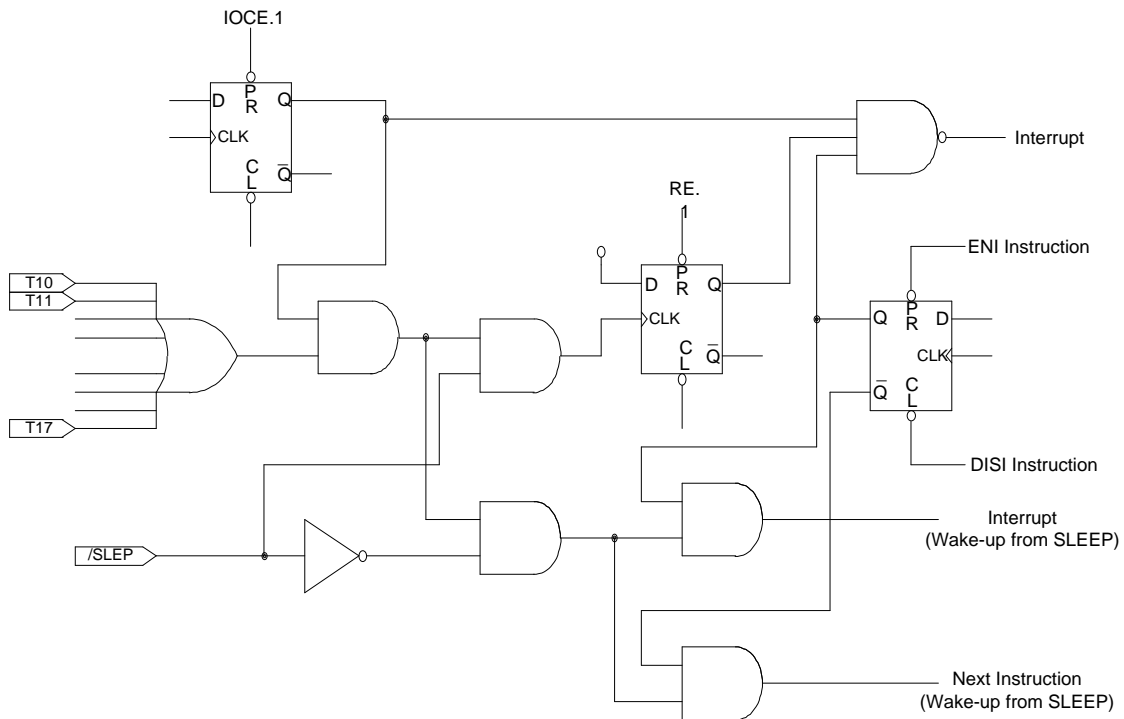

Figure 6-8 Block Diagram of I/O Ports 5-8 with Input Change Interrupt/Wake-up

Table 2 Usage of Ports 5-8 Input Changed Wake-up/Interrupt Function

Usage of Ports 5-8 Input Status Changed Wake-up/Interrupt	
(I) Wake-up	(II) Wake-up and interrupt
(a) Before SLEEP	(a) Before SLEEP
1. Disable WDT	1. Disable WDT
2. Read I/O Port (MOV R6,R6)	2. Read I/O Port (MOV R6,R6)
3. Execute "ENI" or "DISI"	3. Execute "ENI" or "DISI"
4. Enable wake-up bit (Set ICWKP _x *=1) *x = 8~5	4. Enable wake-up bit (Set ICWKP _x *=1) *x = 8~5
5. Execute "SLEEP" instruction	5. Enable interrupt (Set ICIE =1)
(b) After wake-up	6. Execute "SLEEP" instruction
→ Next instruction	(b) After wake-up
	1. IF "ENI" → Interrupt vector (0004H)
	2. IF "DISI" → Next instruction

6.4 Reset and Wake-up

6.4.1 Reset

A Reset can be initiated by any one of the following events: –

- (1) Power on reset.
- (2) /RESET pin input "low"
- (3) WDT time-out (if enabled).
- (4) LVR (if enabled).
- (5) Software Reset (instruction "RESET")

The device is kept in a RESET condition for a period of approx. 16ms² (one oscillator start-up timer period) after the reset is detected. If the /Reset pin goes "low" or WDT time-out is active, a reset is generated, in IRC mode the reset time is WSTO and 8/32 clocks, High XTAL mode reset time is WSTO and 510 clocks. In Low XTAL mode, the reset time is WSTO and 510 clocks (Fs). Once a RESET occurs, the following functions are performed.

Refer to Figure 6-9.

- The oscillator is running, or will be started.
- The Program Counter (R2) is set to all "0".
- All I/O port pins are configured as input mode (high-impedance state).
- The Watchdog timer and prescaler are cleared.
- The bits of the control register are set in Table 3.

The sleep (power down) mode is asserted by executing the "SLEP" instruction. While entering sleep mode, WDT (if enabled) is cleared but keeps on running. After wake-up is generated, in IRC mode the wake-up time is WSTO and 8/32 clocks. , High XTAL mode wake-up time is WSTO and 510 clocks. In low XTAL mode, the wake-up time is WSTO and 510 clocks (Fs).The controller can be awakened by :

- (1) External reset input on /RESET pin,
- (2) WDT time-out (if enabled).
- (3) External (/INT) pin changes (if INTWE is enabled).
- (4) Port input status changes (if ICWKPx is enabled).
- (5) I2C received data when I2C act as slave device (if I2CWK is enabled)

² NOTE: Vdd = 5V, Temp=-40~85°C, WDT time-out period = 16.5ms ± 5%
Vdd = 3V, Temp=-40~85°C, WDT time-out period = 16.5ms ± 5%

- (6) A/D conversion completed (if ADWK is enabled).
- (7) TCC Counter mode overflow occur (if TCIE is enable)

The first two cases will cause the EM88F752N to reset. The T and P flags of R3 can be used to determine the source of the reset (wake-up). Case 3~7 are considered the continuation of program execution and the global interrupt ("ENI" or "DISI" being executed) decides whether or not the controller branches to the interrupt vector following wake-up. If ENI is executed before SLEP, the instruction will begin to execute from the address 0x02~0x40 after wake-up. If DISI is executed before SLEP, the execution will restart from the instruction right next to SLEP after wake-up. Only one of the Cases 3 to 7 can be enabled before entering into sleep mode. That is,

- [a]** If WDT is enabled before SLEP, the EM88F752N can be wake-up only by Case 1 or Case 2. Refer to the section on Interrupt for further details.
- [b]** If External (/INT0, /INT1) pin change is used to wake-up EM88F752N and EXWE bit is enabled before SLEP, WDT must be disabled. Hence, the EM88F752N can be wake-up only by Case 3.
- [c]** If Port Input Status Change is used to wake-up EM88F752N and corresponding wake-up setting is enabled before SLEP, WDT must be disabled. Hence, the EM88F752N can be wake-up only by Case 4.
- [d]** When SPI act as slave device, after received data will wake-up EM88F752N and I2CWK bit of Bank0 R11 register is enabled before SLEP, WDT must be disabled by software. Hence, the EM88F752N can be wake-up only by Case 5.
- [e]** If AD conversion completed is used to wake-up EM88F752N and ADWK bit of Bank0 R10 register is enabled before SLEP, WDT must be disabled by software. Hence, the EM88F752N can be wake-up only by Case 6.
- [f]** When TCC Counter mode use external signal overflow occur is used to wake-up EM88F752N and TCIE bit of Bank0 R1B register is enabled before SLEP, WDT must be disabled by software. Hence, the EM88F752N can be waken-up only by Case 7.

Table 3 All kinds of wake-up mode and interrupt mode are shown below:

Wake-up Signal	Condition Signal	Sleep Mode		Idle Mode		Green Mode		Normal Mode	
		DISI	ENI	DISI	ENI	DISI	ENI	DISI	ENI
External INT	INTWK = 0, EXIE = 0	INT Pin Disable							
	INTWK = 0, EXIE = 1	Wake-up is invalid				Next Instruction	Interrupt + Interrupt Vector	Next Instruction	Interrupt + Interrupt Vector
	INTWK = 1, EXIE = 0	INT Pin Disable							
	INTWK = 1, EXIE = 1	Wake up + Next Instruction	Wake up + Interrupt Vector	Wake up + Next Instruction	Wake up + Interrupt Vector	Next Instruction	Interrupt + Interrupt Vector	Next Instruction	Interrupt + Interrupt Vector
TCCINT	TCIE = 0	Wake-up is invalid				Interrupt is invalid			
	TCIE = 1	Wake up + Next Instruction (Counter mode)	Wake up + Interrupt Vector (Counter mode)	Wake up + Next Instruction	Wake up + Interrupt Vector	Next Instruction	Interrupt + Interrupt Vector	Next Instruction	Interrupt + Interrupt Vector
PWMA/B (When TimerA/B Match PRD A/B)	PWMxPIE = 0	Wake-up is invalid				Interrupt is invalid			
	PWMxPIE = 1	wake-up is invalid		Wake up + Next Instruction	Wake up + Interrupt Vector	Next Instruction	Interrupt + Interrupt Vector	Next Instruction	Interrupt + Interrupt Vector
PWMA/B (When TimerA/B Match DTA/B)	PWMxDIE = 0	Wake-up is invalid				Interrupt is invalid			
	PWMxDIE = 1	wake-up is invalid		Wake up + Next Instruction	Wake up + Interrupt Vector	Next Instruction	Interrupt + Interrupt Vector	Next Instruction	Interrupt + Interrupt Vector
TC1/2/3 Interrupt (Used as timer)	TC1/2/3IE = 0	Wake-up is invalid.		Wake-up is invalid.		Interrupt is invalid		Interrupt is invalid	
	TC1/2/3IE = 1	Wake-up is invalid		Wake up + Next Instruction	Wake up + Interrupt Vector	Next Instruction	Interrupt + Interrupt Vector	Next Instruction	Interrupt + Interrupt Vector
TC1/2/3 Interrupt (Used as counter)	TC1/2/3IE = 0	Wake-up is invalid		Wake-up is invalid.		Interrupt is invalid		Interrupt is invalid	
	TC1/2/3IE = 1	Wake up + Next Instruction	Wake up + Interrupt Vector	Wake up + Next Instruction	Wake up + Interrupt Vector	Next Instruction	Interrupt + Interrupt Vector	Next Instruction	Interrupt + Interrupt Vector
Watch Timer	WTIE = 0	Wake-up is invalid.		Wake-up is invalid.		Interrupt is invalid		Interrupt is invalid	
	WTIE = 1	Wake-up is invalid.		Wake up + Next Instruction	Wake up + Interrupt Vector	Next Instruction	Interrupt + Interrupt Vector	Next Instruction	Interrupt + Interrupt Vector

Wake-up Signal	Condition Signal	Sleep Mode		Idle Mode		Green Mode		Normal Mode	
		DISI	ENI	DISI	ENI	DISI	ENI	DISI	ENI
Pin ChangeINT	WKPxH/L = 0, PxCIE = 0	Wake-up is invalid				Interrupt is invalid			
	WKPxH/L = 0, PxCIE = 1	Wake-up is invalid				Next Instruction	Interrupt + Interrupt Vector	Next Instruction	Interrupt + Interrupt Vector
	WKPxH/L = 1, PxCIE = 0	Wake up + Next Instruction				Interrupt is invalid			
	WKPxH/L = 1, PxCIE = 1	Wake up + Next Instruction	Wake up + Interrupt Vector	Wake up + Next Instruction	Wake up + Interrupt Vector	Next Instruction	Interrupt + Interrupt Vector	Next Instruction	Interrupt + Interrupt Vector
Low Voltage Detector INT	LVDWK = 0, LVDIE = 0	Wake up is invalid				Interrupt is invalid			
	LVDWK = 0, LVDIE = 1	Wake up is invalid				Next Instruction	Interrupt + Interrupt Vector	Next Instruction	Interrupt + Interrupt Vector
	LVDWK = 1, LVDIE = 0	Wake up + Next Instruction		Wake up + Next Instruction		Interrupt is invalid			
	LVDWK = 1, LVDIE = 1	Wake up + Next Instruction	Wake up + Next Instruction	Wake up + Next Instruction	Wake up + Next Instruction	Next Instruction	Interrupt + Interrupt Vector	Next Instruction	Interrupt + Interrupt Vector
ADINT	ADWK = 0, ADIE = 0	Wake-up is invalid				Interrupt is invalid			
	ADWK = 0, ADIE = 1	Wake-up is invalid				Next Instruction	Interrupt + Interrupt Vector	Next Instruction	Interrupt + Interrupt Vector
	ADWK = 1, ADIE = 0	Wake up + Next Instruction Fs and Fm don't stop				Interrupt is invalid			
	ADWK = 1, ADIE = 1	Wake up + Next Instruction Fs and Fm don't stop	Wake up + Interrupt Vector Fs and Fm don't stop	Wake up + Next Instruction Fs and Fm don't stop	Wake up + Interrupt Vector Fs and Fm don't stop	Next Instruction	Interrupt + Interrupt Vector	Next Instruction	Interrupt + Interrupt Vector
I2C (Slave mode)	I2CWK = 0, I2CxIE = 0	Wake-up is invalid				I2C Cannot be used		Interrupt is invalid	
	I2CWK = 0, I2CxIE = 1	Wake-up is invalid				I2C Cannot be used		Next Instruction	Interrupt + Interrupt Vector
	I2CWK = 1, I2CxIE = 0	Wake up + Next Instruction I2C must be slave mode				I2C Cannot be used		Interrupt is invalid	
	I2CWK = 1, I2CxIE = 1	Wake up + Next Instruction	Wake up + Interrupt Vector	Wake up + Next Instruction	Wake up + Interrupt Vector	I2C Cannot be used		Next Instruction	Interrupt + Interrupt Vector

Wake-up Signal	Condition Signal	Sleep Mode		Idle Mode		Green Mode		Normal Mode	
		DISI	ENI	DISI	ENI	DISI	ENI	DISI	ENI
WDT Time out		RESET	RESET	RESET	RESET	RESET	RESET	RESET	RESET

After wake up:

1. If interrupt enable → interrupt+ next instruction
2. If interrupt disable → next instruction

6.4.2 Status of RST, T, and P of Status Register

A RESET condition is initiated by the following events:

1. A power-on condition,
2. A high-low-high pulse on /RESET pin
3. Watchdog Timer time-out.
4. LVR occur

The values of T and P, listed in Table 4 are used to check how the processor wakes up. Table 5 shows the events that may affect the status of T and P.

Table 4 Values of RST, T and P after RESET

Reset Type	T	P
Power on	1	1
/RESET during Operating mode	*P	*P
/RESET wake-up during SLEEP mode	1	0
WDT during Operating mode	0	*P
WDT wake-up during SLEEP mode	0	0
Wake-up on pin change during SLEEP mode	1	0

*P: Previous status before reset

Table 5 Status of T and P Being Affected by Events

Event	T	P
Power on	1	1
WDTC instruction	1	1
WDT time-out	0	*P
SLEP instruction	1	0
Wake-up on pin change during SLEEP mode	1	0

*P: Previous value before reset

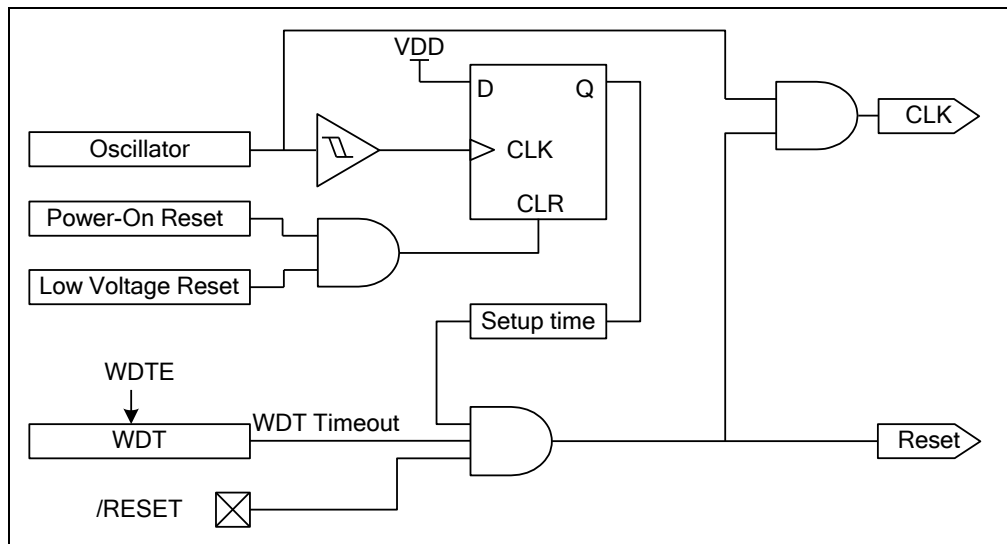

Figure 6-9 Block Diagram of Controller Reset

Table 6 Summary of the Initialized Values for Registers

Address	Bank Name	Reset Type	Bit 7	Bit 6	Bit 5	Bit 4	Bit 3	Bit 2	Bit 1	Bit 0
0x00	R0 (IAR)	Bit Name	IAR7	IAR6	IAR5	IAR4	IAR3	IAR2	IAR1	IAR0
		Power-On	U	U	U	U	U	U	U	U
		/RESET and WDT	P	P	P	P	P	P	P	P
		Wake-Up from Sleep/Idle	P	P	P	P	P	P	P	P
0x01	R1 (BSR)	Bit Name	-	-	SBS1	SBS0	-	-	-	GBS0
		Power-On	0	0	0	0	0	0	0	0
		/RESET and WDT	0	0	0	0	0	0	0	0
		Wake-Up from Sleep/Idle	0	0	P	P	0	0	P	P
0x02	R2 (PCL)	Bit Name	-	-	-	-	-	-	-	-
		Power-On	0	0	0	0	0	0	0	0
		/RESET and WDT	0	0	0	0	0	0	0	0
		Wake-Up from Sleep/Idle	P	P	P	P	P	P	P	P
0x03	R3 (SR)	Bit Name	INT	N	OV	T	P	Z	DC	C
		Power-On	0	U	U	1	1	U	U	U
		/RESET and WDT	0	P	P	t	t	P	P	P
		Wake-Up from Sleep/Idle	P	P	P	t	t	P	P	P
0x04	R4 (RSR)	Bit Name	RSR7	RSR6	RSR5	RSR4	RSR3	RSR2	RSR1	RSR0
		Power-On	U	U	U	U	U	U	U	U
		/RESET and WDT	P	P	P	P	P	P	P	P
		Wake-Up from Sleep/Idle	P	P	P	P	P	P	P	P
0x05	Bank 0, R5 (Port 5)	Bit Name	P57	P56	P55	P54	P53	P52	P51	P50
		Power-On	0	0	0	0	0	0	0	0
		/RESET and WDT	0	0	0	0	0	0	0	0
		Wake-Up from Sleep/Idle	P	P	P	P	P	P	P	P
0x06	Bank 0, R6 (Port 6)	Bit Name	-	-	-	P64	P63	P62	P61	P60
		Power-On	0	0	0	0	0	0	0	0
		/RESET and WDT	0	0	0	0	0	0	0	0
		Wake-Up from Sleep/Idle	P	P	P	P	P	P	P	P

Address	Bank Name	Reset Type	Bit 7	Bit 6	Bit 5	Bit 4	Bit 3	Bit 2	Bit 1	Bit 0
0x08	Bank 0, R8 (Port 8)	Bit Name	-	-	-	P84	P83	P82	P81	P80
		Power-On	0	0	0	0	0	0	0	0
		/RESET and WDT	0	0	0	0	0	0	0	0
		Wake-Up from Sleep/Idle	P	P	P	P	P	P	P	P
0x0B	Bank 0, RB (IOCR5)	Bit Name	IOC57	IOC56	IOC55	IOC54	IOC53	IOC52	IOC51	IOC50
		Power-On	1	1	1	1	1	1	1	1
		/RESET and WDT	1	1	1	1	1	1	1	1
		Wake-Up from Sleep/Idle	P	P	P	P	P	P	P	P
0x0C	Bank 0, RC (IOCR6)	Bit Name	-	-	-	IOC64	IOC63	IOC62	IOC61	IOC60
		Power-On	1	1	1	1	1	1	1	1
		/RESET and WDT	1	1	1	1	1	1	1	1
		Wake-Up from Sleep/Idle	P	P	P	P	P	P	P	P
0x0E	Bank 0, RE (OMCR)	Bit Name	CPUS	IDLE	-	-	-	RCM2	RCM1	RCM0
		Power-On	Code option (HLFS)	1	0	0	0	Code option (RCM2)	Code option (RCM1)	Code option (RCM0)
		/RESET and WDT	Code option (HLFS)	1	0	0	0	C	C	C
		Wake-Up from Sleep/Idle	P	P	0	0	0	P	P	P
0x0F	Bank 0, RF EIESCR	Bit Name	-	-	-	-	EIES1	EIES0	-	-
		Power-On	0	0	0	0	1	1	0	0
		/RESET and WDT	0	0	0	0	1	1	0	0
		Wake-Up from Sleep/Idle	0	0	0	0	P	P	0	0
0x10	Bank 0, R10 (WUCR1)	Bit Name	-	-	LVDWK	ADWK	INT1WK	INT0WK	-	-
		Power-On	0	0	0	0	0	0	0	0
		/RESET and WDT	0	0	0	0	0	0	0	0
		Wake-Up from Sleep/Idle	0	0	P	P	P	P	0	0
0x11	Bank 0, R11 WUCR2	Bit Name	-	-	-	-	-	I2CWK	-	-
		Power-On	0	0	0	0	0	0	0	0
		/RESET and WDT	0	0	0	0	0	0	0	0
		Wake-Up from Sleep/Idle	0	0	0	0	P	P	0	0



Address	Bank Name	Reset Type	Bit 7	Bit 6	Bit 5	Bit 4	Bit 3	Bit 2	Bit 1	Bit 0
0x12	Bank 0, R12 WUCR3	Bit Name	ICWKP8	ICWKP7	ICWKP6	ICWKP5	-	-	-	-
		Power-On	0	0	0	0	0	0	0	0
		/RESET and WDT	0	0	0	0	0	0	0	0
		Wake-Up from Sleep/Idle	P	P	P	P	0	0	0	0
0x14	Bank 0, R14 SFR1	Bit Name	-	-	LVDSF	ADSF	EXSF1	EXSF0	WTSF	TCSF
		Power-On	0	0	0	0	0	0	0	0
		/RESET and WDT	0	0	0	0	0	0	0	0
		Wake-Up from Sleep/Idle	0	0	P	P	P	P	P	P
0x15	Bank 0, R15 SFR2	Bit Name	-	-	-	-	-	TC3SF	TC2SF	TC1SF
		Power-On	0	0	0	0	0	0	0	0
		/RESET and WDT	0	0	0	0	0	0	0	0
		Wake-Up from Sleep/Idle	0	0	0	0	0	P	P	P
0x16	Bank 0, R16 SFR3	Bit Name	-	-	-	-	PWMBP SF	PWMBD SF	PWMAP SF	PWMAD SF
		Power-On	0	0	0	0	0	0	0	0
		/RESET and WDT	0	0	0	0	0	0	0	0
		Wake-Up from Sleep/Idle	0	0	0	0	P	P	P	P
0x17	Bank 0, R17 SFR4	Bit Name	P8ICSF	-	P6ICSF	P5ICSF	-	I2CSTPS F	I2CRSF	I2CTSF
		Power-On	0	0	0	0	0	0	0	0
		/RESET and WDT	0	0	0	0	0	0	0	0
		Wake-Up from Sleep/Idle	P	P	P	P	P	P	P	P
0x19	Bank 0, R19 SFR6	Bit Name	SHSF	-	-	-	-	-	-	-
		Power-On	0	0	0	0	0	0	0	0
		/RESET and WDT	0	0	0	0	0	0	0	0
		Wake-Up from Sleep/Idle	P	0	0	0	0	0	0	0
0x1B	Bank 0, R1B IMR1	Bit Name	-	-	LVDIE	ADIE	EXIE1	EXIE0	WTIE	TCIE
		Power-On	0	0	0	0	0	0	0	0
		/RESET and WDT	0	0	0	0	0	0	0	0
		Wake-Up from Sleep/Idle	0	0	P	P	P	P	P	P



Address	Bank Name	Reset Type	Bit 7	Bit 6	Bit 5	Bit 4	Bit 3	Bit 2	Bit 1	Bit 0
0X1C	Bank 0, R1C IMR2	Bit Name	-	-	-	-	-	TC3IE	TC2IE	TC1IE
		Power-On	0	0	0	0	0	0	0	0
		/RESET and WDT	0	0	0	0	0	0	0	0
		Wake-Up from Sleep/Idle	0	0	0	0	0	P	P	P
0X1D	Bank 0, R1D IMR3	Bit Name	-	-	-	-	PWMBPIE	PWMBDIE	PWMAPIE	PWMAIDIE
		Power-On	0	0	0	0	0	0	0	0
		/RESET and WDT	0	0	0	0	0	0	0	0
		Wake-Up from Sleep/Idle	0	0	0	0	P	P	P	P
0X1E	Bank 0, R1E IMR4	Bit Name	P8ICIE	-	P6ICIE	P5ICIE	-	I2CSTPIE	I2CRIE	I2CTIE
		Power-On	0	0	0	0	0	0	0	0
		/RESET and WDT	0	0	0	0	0	0	0	0
		Wake-Up from Sleep/Idle	P	P	P	P	P	P	P	P
0X21	Bank 0, R21 WDTCR	Bit Name	WDTE	-	-	-	PSWE	WPSR2	WPSR1	WPSR0
		Power-On	0	0	0	0	0	0	0	0
		/RESET and WDT	0	0	0	0	0	0	0	0
		Wake-Up from Sleep/Idle	P	0	0	0	P	P	P	P
0X20	Bank 0, R20 IMR6	Bit Name	SHIE	-	-	-	-	-	-	-
		Power-On	0	0	0	0	0	0	0	0
		/RESET and WDT	0	0	0	0	0	0	0	0
		Wake-Up from Sleep/Idle	P	0	0	0	0	0	0	0
0X22	Bank 0, R22 TCCCR	Bit Name	-	TCCS	TS	TE	PSTE	TPSR2	TPSR1	TPSR0
		Power-On	0	0	0	0	0	0	0	0
		/RESET and WDT	0	0	0	0	0	0	0	0
		Wake-Up from Sleep/Idle	0	P	P	P	P	P	P	P
0X23	Bank 0, R23 TCCD	Bit Name	TCC7	TCC6	TCC5	TCC4	TCC3	TCC2	TCC1	TCC0
		Power-On	0	0	0	0	0	0	0	0
		/RESET and WDT	0	0	0	0	0	0	0	0
		Wake-Up from Sleep/Idle	P	P	P	P	P	P	P	P

Address	Bank Name	Reset Type	Bit 7	Bit 6	Bit 5	Bit 4	Bit 3	Bit 2	Bit 1	Bit 0
0X24	Bank 0, R24 TC1CR1	Bit Name	TC1S	TC1RC	TC1SS1	TC1MOD	TC1FF	TC1MOS	TC1IS1	TC1IS0
		Power-On	0	0	0	0	0	0	0	0
		/RESET and WDT	0	0	0	0	0	0	0	0
		Wake-Up from Sleep/Idle	P	P	P	P	P	P	P	P
0X25	Bank 0, R25 TC1CR2	Bit Name	TC1M2	TC1M1	TC1M0	TC1SS0	TC1CK3	TC1CK2	TC1CK1	TC1CK0
		Power-On	0	0	0	0	0	0	0	0
		/RESET and WDT	0	0	0	0	0	0	0	0
		Wake-Up from Sleep/Idle	P	P	P	P	P	P	P	P
0X26	Bank 0, R26 TC1DA	Bit Name	TC1DA7	TC1DA6	TC1DA5	TC1DA4	TC1DA3	TC1DA2	TC1DA1	TC1DA0
		Power-On	0	0	0	0	0	0	0	0
		/RESET and WDT	0	0	0	0	0	0	0	0
		Wake-Up from Sleep/Idle	P	P	P	P	P	P	P	P
0X27	Bank 0, R27 TC1DB	Bit Name	TC1DB7	TC1DB6	TC1DB5	TC1DB4	TC1DB3	TC1DB2	TC1DB1	TC1DB0
		Power-On	0	0	0	0	0	0	0	0
		/RESET and WDT	0	0	0	0	0	0	0	0
		Wake-Up from Sleep/Idle	P	P	P	P	P	P	P	P
0X28	Bank 0, R28 TC2CR1	Bit Name	TC2S	TC2RC	TC2SS1		TC2FF	TC2MOS	TC2IS1	TC2IS0
		Power-On	0	0	0	0	0	0	0	0
		/RESET and WDT	0	0	0	0	0	0	0	0
		Wake-Up from Sleep/Idle	P	P	P	0	P	P	P	P
0X29	Bank 0, R29 TC2CR2	Bit Name	TC2M2	TC2M1	TC2M0	TC2SS0	TC2CK3	TC2CK2	TC2CK1	TC2CK0
		Power-On	0	0	0	0	0	0	0	0
		/RESET and WDT	0	0	0	0	0	0	0	0
		Wake-Up from Sleep/Idle	P	P	P	P	P	P	P	P
0X2A	Bank 0, R2A TC2DA	Bit Name	TC2DA7	TC2DA6	TC2DA5	TC2DA4	TC2DA3	TC2DA2	TC2DA1	TC2DA0
		Power-On	0	0	0	0	0	0	0	0
		/RESET and WDT	0	0	0	0	0	0	0	0
		Wake-Up from Sleep/Idle	P	P	P	P	P	P	P	P



Address	Bank Name	Reset Type	Bit 7	Bit 6	Bit 5	Bit 4	Bit 3	Bit 2	Bit 1	Bit 0
0X2B	Bank 0, R2B TC2DB	Bit Name	TC2DB7	TC2DB6	TC2DB5	TC2DB4	TC2DB3	TC2DB2	TC2DB1	TC2DB0
		Power-On	0	0	0	0	0	0	0	0
		/RESET and WDT	0	0	0	0	0	0	0	0
		Wake-Up from Sleep/Idle	P	P	P	P	P	P	P	P
0X2C	Bank 0, R2C TC3CR1	Bit Name	TC3S	TC3RC	TC3SS1		TC3FF	TC3MOS	TC3IS1	TC3IS0
		Power-On	0	0	0	0	0	0	0	0
		/RESET and WDT	0	0	0	0	0	0	0	0
		Wake-Up from Sleep/Idle	P	P	P	0	P	P	P	P
0X2D	Bank 0, R2D TC3CR2	Bit Name	TC3M2	TC3M1	TC3M0	TC3SS0	TC3CK3	TC3CK2	TC3CK1	TC3CK0
		Power-On	0	0	0	0	0	0	0	0
		/RESET and WDT	0	0	0	0	0	0	0	0
		Wake-Up from Sleep/Idle	P	P	P	P	P	P	P	P
0X2E	Bank 0, R2E TC3DA	Bit Name	TC3DA7	TC3DA6	TC3DA5	TC3DA4	TC3DA3	TC3DA2	TC3DA1	TC3DA0
		Power-On	0	0	0	0	0	0	0	0
		/RESET and WDT	0	0	0	0	0	0	0	0
		Wake-Up from Sleep/Idle	P	P	P	P	P	P	P	P
0X2F	Bank 0, R2F TC3DB	Bit Name	TC3DB7	TC3DB6	TC3DB5	TC3DB4	TC3DB3	TC3DB2	TC3DB1	TC3DB0
		Power-On	0	0	0	0	0	0	0	0
		/RESET and WDT	0	0	0	0	0	0	0	0
		Wake-Up from Sleep/Idle	P	P	P	P	P	P	P	P
0X30	Bank 0, R30 I2CCR1	Bit Name	Strobe /Pend	IMS	ISS	STOP	SAR_EMPTY	ACK	FULL	EMPTY
		Power-On	0	0	0	0	1	0	0	1
		/RESET and WDT	0	0	0	0	1	0	0	1
		Wake-Up from Sleep/Idle	P	P	P	P	P	P	P	P
0X31	Bank 0, R31 I2CCR2	Bit Name	I2CBF	GCEN	I2COPT	BBF	I2CTS2	I2CTS1	I2CTS0	I2CEN
		Power-On	0	0	Code option (I2COPT)	0	0	0	0	0
		/RESET and WDT	0	0	C	0	0	0	0	0
		Wake-Up from Sleep/Idle	P	P	P	P	P	P	P	P

Address	Bank Name	Reset Type	Bit 7	Bit 6	Bit 5	Bit 4	Bit 3	Bit 2	Bit 1	Bit 0
0X32	Bank 0, R32 I2CSA	Bit Name	SA6	SA5	SA4	SA3	SA2	SA1	SA0	IRW
		Power-On	0	0	0	0	0	0	0	0
		/RESET and WDT	0	0	0	0	0	0	0	0
		Wake-Up from Sleep/Idle	P	P	P	P	P	P	P	P
0X33	Bank 0, R33 I2CDB	Bit Name	DB7	DB6	DB5	DB4	DB3	DB2	DB1	DB0
		Power-On	0	0	0	0	0	0	0	0
		/RESET and WDT	0	0	0	0	0	0	0	0
		Wake-Up from Sleep/Idle	P	P	P	P	P	P	P	P
0X34	Bank 0, R34 I2CDAL	Bit Name	DA7	DA6	DA5	DA4	DA3	DA2	DA1	DA0
		Power-On	1	1	1	1	1	1	1	1
		/RESET and WDT	1	1	1	1	1	1	1	1
		Wake-Up from Sleep/Idle	P	P	P	P	P	P	P	P
0X35	Bank 0, R35 I2CDAH	Bit Name	-	-	-	-	-	-	DA9	DA8
		Power-On	0	0	0	0	0	0	1	1
		/RESET and WDT	0	0	0	0	0	0	1	1
		Wake-Up from Sleep/Idle	0	0	0	0	0	0	P	P
0X3E	Bank 0, R3E ADCR1	Bit Name	CKR2	CKR1	CKR0	ADRUN	ADP	ADOM	SHS1	SHS0
		Power-On	0	0	0	0	0	0	0	0
		/RESET and WDT	0	0	0	0	0	0	0	0
		Wake-Up from Sleep/Idle	P	P	P	P	P	P	P	P
0X3F	Bank 0, R3F ADCR2	Bit Name	-	VPIS2	ADIM	ADCMS	VPIS1	VPIS0	VREFP	-
		Power-On	0	0	0	0	0	0	0	0
		/RESET and WDT	0	0	0	0	0	0	0	0
		Wake-Up from Sleep/Idle	0	P	P	P	P	P	P	0
0X40	Bank 0, R40 ADISR	Bit Name	-	-	-	-	ADIS3	ADIS2	ADIS1	ADIS0
		Power-On	0	0	0	0	0	0	0	0
		/RESET and WDT	0	0	0	0	0	0	0	0
		Wake-Up from Sleep/Idle	0	0	0	0	P	P	P	P

Address	Bank Name	Reset Type	Bit 7	Bit 6	Bit 5	Bit 4	Bit 3	Bit 2	Bit 1	Bit 0
0X41	Bank 0, R41 ADER1	Bit Name	ADE7	ADE6	ADE5	ADE4	ADE3	ADE2	ADE1	ADE0
		Power-On	0	0	0	0	0	0	0	0
		/RESET and WDT	0	0	0	0	0	0	0	0
		Wake-Up from Sleep/Idle	P	P	P	P	P	P	P	P
0X43	Bank 0, R43 ADDL	Bit Name	ADD7	ADD6	ADD5	ADD4	ADD3	ADD2	ADD1	ADD0
		Power-On	U	U	U	U	U	U	U	U
		/RESET and WDT	P	P	P	P	P	P	P	P
		Wake-Up from Sleep/Idle	P	P	P	P	P	P	P	P
0X44	Bank 0, R44 ADDH	Bit Name	ADD15	ADD14	ADD13	ADD12	ADD11	ADD10	ADD9	ADD8
		Power-On	U	U	U	U	U	U	U	U
		/RESET and WDT	P	P	P	P	P	P	P	P
		Wake-Up from Sleep/Idle	P	P	P	P	P	P	P	P
0X45	Bank 0, R45 ADCVL	Bit Name	ADCD7	ADCD6	ADCD5	ADCD4	ADCD3	ADCD2	ADCD1	ADCD0
		Power-On	0	0	0	0	0	0	0	0
		/RESET and WDT	P	P	P	P	P	P	P	P
		Wake-Up from Sleep/Idle	P	P	P	P	P	P	P	P
0X46	Bank 0, R46 ADCVH	Bit Name	ADCD15	ADCD14	ADCD13	ADCD12	ADCD11	ADCD10	ADCD9	ADCD8
		Power-On	0	0	0	0	0	0	0	0
		/RESET and WDT	P	P	P	P	P	P	P	P
		Wake-Up from Sleep/Idle	P	P	P	P	P	P	P	P
0X05	Bank 1, R5 IOCR8	Bit Name	-	-	-	IOC84	IOC83	IOC82	IOC81	IOC80
		Power-On	1	1	1	1	1	1	1	1
		/RESET and WDT	1	1	1	1	1	1	1	1
		Wake-Up from Sleep/Idle	P	P	P	P	P	P	P	P
0X08	Bank 1, R8 P5PHCR	Bit Name	PH57	PH56	PH55	PH54	PH53	PH52	PH51	PH50
		Power-On	1	1	1	1	1	1	1	1
		/RESET and WDT	1	1	1	1	1	1	1	1
		Wake-Up from Sleep/Idle	P	P	P	P	P	P	P	P

Address	Bank Name	Reset Type	Bit 7	Bit 6	Bit 5	Bit 4	Bit 3	Bit 2	Bit 1	Bit 0
0X09	Bank 1, R9 P6PHCR	Bit Name	-	-	-	PH64	PH63	PH62	PH61	PH60
		Power-On	1	1	1	1	1	1	1	1
		/RESET and WDT	1	1	1	1	1	1	1	1
		Wake-Up from Sleep/Idle	P	P	P	P	P	P	P	P
0X0A	Bank 1, RA P8PHCR	Bit Name	-	-	-	-	P8HPH	P8LPH	-	-
		Power-On	0	1	1	1	1	1	1	1
		/RESET and WDT	0	1	1	1	1	1	1	1
		Wake-Up from Sleep/Idle	0	P	P	P	P	P	P	P
0X0B	Bank 1, RB P5PLCR	Bit Name	PL57	PL56	PL55	PL54	PL53	PL52	PL51	PL50
		Power-On	1	1	1	1	1	1	1	1
		/RESET and WDT	1	1	1	1	1	1	1	1
		Wake-Up from Sleep/Idle	P	P	P	P	P	P	P	P
0X0C	Bank 1, RC P6PLCR	Bit Name	-	-	-	PL64	PL63	PL62	PL61	PL60
		Power-On	1	1	1	1	1	1	1	1
		/RESET and WDT	1	1	1	1	1	1	1	1
		Wake-Up from Sleep/Idle	P	P	P	P	P	P	P	P
0X0D	Bank 1, RD P8PLCR	Bit Name	-	-	-	-	P8HPL	P8LPL	-	-
		Power-On	0	1	1	1	1	1	1	1
		/RESET and WDT	0	1	1	1	1	1	1	1
		Wake-Up from Sleep/Idle	0	P	P	P	P	P	P	P
0X0E	Bank 1, RE P5HDSCR	Bit Name	H57	H56	H55	H54	H53	H52	H51	H50
		Power-On	1	1	1	1	1	1	1	1
		/RESET and WDT	1	1	1	1	1	1	1	1
		Wake-Up from Sleep/Idle	P	P	P	P	P	P	P	P
0X0F	Bank 1, RF P6HDSCR	Bit Name	-	-	-	H64	H63	H62	H61	H60
		Power-On	1	1	1	1	1	1	1	1
		/RESET and WDT	1	1	1	1	1	1	1	1
		Wake-Up from Sleep/Idle	P	P	P	P	P	P	P	P



Address	Bank Name	Reset Type	Bit 7	Bit 6	Bit 5	Bit 4	Bit 3	Bit 2	Bit 1	Bit 0
0X10	Bank 1, R10 P8HDSCR	Bit Name	-	-	-	-	P8HHDS	P8LHDS	-	-
		Power-On	0	1	1	1	1	1	1	1
		/RESET and WDT	0	1	1	1	1	1	1	1
		Wake-Up from Sleep/Idle	0	P	P	P	P	P	P	P
0X11	Bank 1, R11 P5ODCR	Bit Name	OD57	OD56	OD55	OD54	OD53	OD52	OD51	OD50
		Power-On	0	0	0	0	0	0	0	0
		/RESET and WDT	0	0	0	0	0	0	0	0
		Wake-Up from Sleep/Idle	P	P	P	P	P	P	P	P
0X12	Bank 1, R12 P6ODCR	Bit Name	-	-	-	OD64	OD63	OD62	OD61	OD60
		Power-On	0	0	0	0	0	0	0	0
		/RESET and WDT	0	0	0	0	0	0	0	0
		Wake-Up from Sleep/Idle	P	P	P	P	P	P	P	P
0X13	Bank 1, R13 P8ODCR	Bit Name	-	-	-	-	P8HOD	P8LOD	-	-
		Power-On	0	0	0	0	0	0	0	0
		/RESET and WDT	0	0	0	0	0	0	0	0
		Wake-Up from Sleep/Idle	0	P	P	P	P	P	P	P
0x14	Bank 1, R14 DeadTCR	Bit Name	-	-	-	-	DEADTP 3	DEADTP 2	DEADTP 1	DEADTP 0
		Power-On	0	0	0	0	0	0	0	0
		/RESET and WDT	0	0	0	0	0	0	0	0
		Wake-Up from Sleep/Idle	0	0	0	0	P	P	P	P
0x15	Bank 1, R15 DeadTR	Bit Name	DEADTR 7	DEADTR 6	DEADTR 5	DEADTR 4	DEADTR 3	DEADTR 2	DEADTR 1	DEADTR 0
		Power-On	0	0	0	0	0	0	0	0
		/RESET and WDT	0	0	0	0	0	0	0	0
		Wake-Up from Sleep/Idle	P	P	P	P	P	P	P	P
0X16	Bank 1, R16 PWMSCR	Bit Name	-	-	-	DEADS	-	-	PWMBS	PWMAS
		Power-On	0	0	0	0	0	0	0	0
		/RESET and WDT	0	0	0	0	0	0	0	0
		Wake-Up from Sleep/Idle	0	0	0	P	0	0	P	P



Address	Bank Name	Reset Type	Bit 7	Bit 6	Bit 5	Bit 4	Bit 3	Bit 2	Bit 1	Bit 0
0X17	Bank 1, R17 PWMA CR	Bit Name	PWMAE	IPWMAE	PWMAA	IPWMAA	TAEN	TAP2	TAP1	TAP0
		Power-On	0	0	0	0	0	0	0	0
		/RESET and WDT	0	0	0	0	0	0	0	0
		Wake-Up from Sleep/Idle	P	P	P	P	P	P	P	P
0X18	Bank 1, R18 PRDA L	Bit Name	PRDA7	PRDA6	PRDA5	PRDA4	PRDA3	PRDA2	PRDA1	PRDA0
		Power-On	0	0	0	0	0	0	0	0
		/RESET and WDT	0	0	0	0	0	0	0	0
		Wake-Up from Sleep/Idle	P	P	P	P	P	P	P	P
0X19	Bank 1, R19 PRDA H	Bit Name	PRDA15	PRDA14	PRDA13	PRDA12	PRDA11	PRDA10	PRDA9	PRDA8
		Power-On	0	0	0	0	0	0	0	0
		/RESET and WDT	0	0	0	0	0	0	0	0
		Wake-Up from Sleep/Idle	P	P	P	P	P	P	P	P
0X1A	Bank 1, R1A DTA L	Bit Name	DTA7	DTA6	DTA5	DTA4	DTA3	DTA2	DTA1	DTA0
		Power-On	0	0	0	0	0	0	0	0
		/RESET and WDT	0	0	0	0	0	0	0	0
		Wake-Up from Sleep/Idle	P	P	P	P	P	P	P	P
0X1B	Bank 1, R1B DTA H	Bit Name	DTA15	DTA14	DTA13	DTA12	DTA11	DTA10	DTA9	DTA8
		Power-On	0	0	0	0	0	0	0	0
		/RESET and WDT	0	0	0	0	0	0	0	0
		Wake-Up from Sleep/Idle	P	P	P	P	P	P	P	P
0X1C	Bank 1, R1C TMRA L	Bit Name	TMRA7	TMRA6	TMRA5	TMRA4	TMRA3	TMRA2	TMRA1	TMRA0
		Power-On	0	0	0	0	0	0	0	0
		/RESET and WDT	0	0	0	0	0	0	0	0
		Wake-Up from Sleep/Idle	P	P	P	P	P	P	P	P
0X1D	Bank 1, R1D TMRA H	Bit Name	TMRA15	TMRA14	TMRA13	TMRA12	TMRA11	TMRA10	TMRA9	TMRA8
		Power-On	0	0	0	0	0	0	0	0
		/RESET and WDT	0	0	0	0	0	0	0	0
		Wake-Up from Sleep/Idle	P	P	P	P	P	P	P	P

Address	Bank Name	Reset Type	Bit 7	Bit 6	Bit 5	Bit 4	Bit 3	Bit 2	Bit 1	Bit 0
0X1E	Bank 1, R1E PWMBCR	Bit Name	PWMBE	IPWMBE	PWMB A	IPWMB A	TBEN	TBP2	TBP1	TBP0
		Power-On	0	0	0	0	0	0	0	0
		/RESET and WDT	0	0	0	0	0	0	0	0
		Wake-Up from Sleep/Idle	P	P	P	P	P	P	P	P
0X1F	Bank 1, R1F PRDBL	Bit Name	PRDB7	PRDB6	PRDB5	PRDB4	PRDB3	PRDB2	PRDB1	PRDB0
		Power-On	0	0	0	0	0	0	0	0
		/RESET and WDT	0	0	0	0	0	0	0	0
		Wake-Up from Sleep/Idle	P	P	P	P	P	P	P	P
0X20	Bank 1, R20 PRDBH	Bit Name	PRDB15	PRDB14	PRDB13	PRDB12	PRDB11	PRDB10	PRDB9	PRDB8
		Power-On	0	0	0	0	0	0	0	0
		/RESET and WDT	0	0	0	0	0	0	0	0
		Wake-Up from Sleep/Idle	P	P	P	P	P	P	P	P
0X21	Bank 1, R21 DTBL	Bit Name	DTB7	DTB6	DTB5	DTB4	DTB3	DTB2	DTB1	DTB0
		Power-On	0	0	0	0	0	0	0	0
		/RESET and WDT	0	0	0	0	0	0	0	0
		Wake-Up from Sleep/Idle	P	P	P	P	P	P	P	P
0X22	Bank 1, R22 DTBH	Bit Name	DTB15	DTB14	DTB13	DTB12	DTB11	DTB10	DTB9	DTB8
		Power-On	0	0	0	0	0	0	0	0
		/RESET and WDT	0	0	0	0	0	0	0	0
		Wake-Up from Sleep/Idle	P	P	P	P	P	P	P	P
0X23	Bank 1, R23 TMRBL	Bit Name	TMRB7	TMRB6	TMRB5	TMRB4	TMRB3	TMRB2	TMRB1	TMRB0
		Power-On	0	0	0	0	0	0	0	0
		/RESET and WDT	0	0	0	0	0	0	0	0
		Wake-Up from Sleep/Idle	P	P	P	P	P	P	P	P
0X24	Bank 1, R24 TMRBH	Bit Name	TMRB15	TMRB14	TMRB13	TMRB12	TMRB11	TMRB10	TMRB9	TMRB8
		Power-On	0	0	0	0	0	0	0	0
		/RESET and WDT	0	0	0	0	0	0	0	0
		Wake-Up from Sleep/Idle	P	P	P	P	P	P	P	P

Address	Bank Name	Reset Type	Bit 7	Bit 6	Bit 5	Bit 4	Bit 3	Bit 2	Bit 1	Bit 0	
0X40	Bank 1, R40 WCR	Bit Name	WTE	WTSSB1	WTSSB0	-	-	-	-	-	
		Power-On	0	0	0	0	0	0	0	0	
		/RESET and WDT	0	0	0	0	0	0	0	0	
		Wake-Up from Sleep/Idle	0	0	0	0	0	0	0	P	P
0X44	Bank 1, R44 FLKR	Bit Name	FLK[7]	FLK[6]	FLK[5]	FLK[4]	FLK[3]	FLK[2]	FLK[1]	FLK[0]	
		Power-On	0	0	0	0	0	0	0	0	0
		/RESET and WDT	0	0	0	0	0	0	0	0	0
		Wake-Up from Sleep/Idle	P	P	P	P	P	P	P	P	P
0X45	Bank 1, R45 TBPTL	Bit Name	TB7	TB6	TB5	TB4	TB3	TB2	TB1	TB0	
		Power-On	0	0	0	0	0	0	0	0	0
		/RESET and WDT	0	0	0	0	0	0	0	0	0
		Wake-Up from Sleep/Idle	P	P	P	P	P	P	P	P	P
0X46	Bank 1, R46 TBPTH	Bit Name	HLB	RDS	-	-	-	TB10	TB9	TB8	
		Power-On	0	0	0	0	0	0	0	0	
		/RESET and WDT	0	0	0	0	0	0	0	0	
		Wake-Up from Sleep/Idle	P	P	0	P	P	P	P	P	
0X47	Bank 1, R47 STKMON	Bit Name	STOV	-	-	-	STL3	STL2	STL1	STL0	
		Power-On	0	0	0	0	0	0	0	0	
		/RESET and WDT	0	0	0	0	0	0	0	0	
		Wake-Up from Sleep/Idle	P	0	0	0	P	P	P	P	
0X48	Bank 1, R48 PCH	Bit Name	-	-	-	-	-	PC10	PC9	PC8	
		Power-On	0	0	0	0	0	0	0	0	
		/RESET and WDT	0	0	0	0	0	0	0	0	
		Wake-Up from Sleep/Idle	0	0	0	P	P	P	P	P	
0X49	Bank 1, R49 LVDCR	Bit Name	LVDEN	-	LVDS1	LVDS0	LVDB	-	-	-	
		Power-On	0	0	0	0	1	0	0	0	
		/RESET and WDT	0	0	0	0	1	0	0	0	
		Wake-Up from Sleep/Idle	P	0	P	P	P	0	0	0	

Address	Bank Name	Reset Type	Bit 7	Bit 6	Bit 5	Bit 4	Bit 3	Bit 2	Bit 1	Bit 0
0X4D	Bank 1, R4D TBWCR	Bit Name	-	-	-	-	-	-	-	IAPEN
		Power-On	0	0	0	0	0	0	0	0
		/RESET and WDT	0	0	0	0	0	0	0	0
		Wake-Up from Sleep/Idle	0	0	0	0	0	0	0	P
0X4E	Bank 1, R4E TBWAL	Bit Name	TBWA [7]	TBWA [6]	TBWA [5]	TBWA [4]	TBWA [3]	TBWA [2]	TBWA [1]	TBWA [0]
		Power-On	0	0	0	0	0	0	0	0
		/RESET and WDT	0	0	0	0	0	0	0	0
		Wake-Up from Sleep/Idle	P	P	P	P	P	P	P	P
0X4F	Bank 1, R4F TBWAH	Bit Name	-	-	-	-	-	TBWA [10]	TBWA [9]	TBWA [8]
		Power-On	0	0	0	0	0	0	0	0
		/RESET and WDT	0	0	0	0	0	0	0	0
		Wake-Up from Sleep/Idle	0	0	0	P	P	P	P	P
0X47	Bank 2, R47 LOCKPR	Bit Name	LOCKPR [7]	LOCKPR [6]	LOCKPR [5]	LOCKPR [4]	LOCKPR [3]	LOCKPR [2]	LOCKPR [1]	LOCKPR [0]
		Power-On	0	0	0	0	0	0	0	0
		/RESET and WDT	0	0	0	0	0	0	0	0
		Wake-Up from Sleep/Idle	P	P	P	P	P	P	P	P
0X48	Bank 2, R48 LOCKCR	Bit Name	LOCKEN	-	-	-	-	-	-	-
		Power-On	0	0	0	0	0	0	0	0
		/RESET and WDT	0	0	0	0	0	0	0	0
		Wake-Up from Sleep/Idle	P	0	0	0	0	0	0	0

U: Unknown or don't care. P: Previous value before reset. C: The same with Code option t: Check Table 6

6.5 Interrupt

The EM88F752N has 20 interrupts (3 external, 14 internal) listed below:

Interrupt Source	Enable Condition	Int. Flag	Int. Vector	Priority	
Internal/External	Reset	-	-	0	High 0
External	INT	ENI + EXIE0=1	EXSF0	2	1
		ENI + EXIE1=1	EXSF1		
External	Pin Change	ENI + P5ICIE=1	P5ICSF	4	2
		ENI + P6ICIE=1	P6ICSF		
		ENI + P7ICIE=1	P7ICSF		
		ENI + P8ICIE=1	P8ICSF		
Internal	TCC	ENI + TCIE=1	TCSF	6	3
Internal	LVD	ENI+LVDEN & LVDIE=1	LVDSF	8	4
Internal	AD	ENI + ADIE=1	ADSF	10	6
Internal	TC1	ENI + TC1IE=1	TC1SF	12	7
Internal	PWMPA	ENI+PWMAPIE=1	PWMA PSF	14	8
Internal	PWMDA	ENI+PWMDIE=1	PWMD PSF	16	9
Internal	I2C Transmit	ENI+ I2CTIE	I2CTS F	1A	10
Internal	I2C Receive	ENI+ I2CRIE	I2CRS F	1C	11
Internal	I2C STOP	ENI+ I2CSTPIE	I2CSTPS F	1E	12
Internal	TC2	ENI + TC2IE=1	TC2SF	22	13
Internal	PWMPB	ENI+PWMBPIE=1	PWMBPS F	24	14
Internal	PWMDB	ENI+PWMBDIE=1	PWMBDS F	26	15
Internal	TC3	ENI + TC3IE=1	TC3SF	28	16
Internal	Watch Timer	ENI + WTIE=1	WTSF	38	17
External	System hold	ENI+SHIE	SHS F	3A	18

Bank0 R14~R19 are the interrupt status registers that record the interrupt requests in the relative flags/bits. Bank0 R1B~R20 is the interrupt mask register. The global interrupt is enabled by the ENI instruction and is disabled by the DISI instruction. When one of the interrupts (enabled) occurs, the next instruction will be fetched from individual address. The interrupt flag bit must be cleared by instructions before leaving the interrupt service routine and before interrupts are enabled to avoid recursive interrupts.

The flag (except ICSF bit delete) in the Interrupt Status Register is set regardless of the status of its mask bit or the execution of ENI. The RETI instruction ends the interrupt routine and enables the global interrupt (the execution of ENI).

External interrupt equipped with digital noise rejection circuit (input pulse less than **4 system clocks time** is eliminated as noise).When an interrupt (Falling edge) is generated by the External interrupt (when enabled), the next instruction will be fetched from Address 002H.

Before the interrupt subroutine is executed, the contents of ACC, R1, R3 (Bits 0~6) and R4 register will be saved by hardware. If another interrupt occurred, the ACC,R1,R3

(Bit 0~Bit 6) and R4 will be replaced by the new interrupt. After the interrupt service routine is finished, ACC,R1,R3 (Bit 0~Bit 6) and R4 will be pushed back.

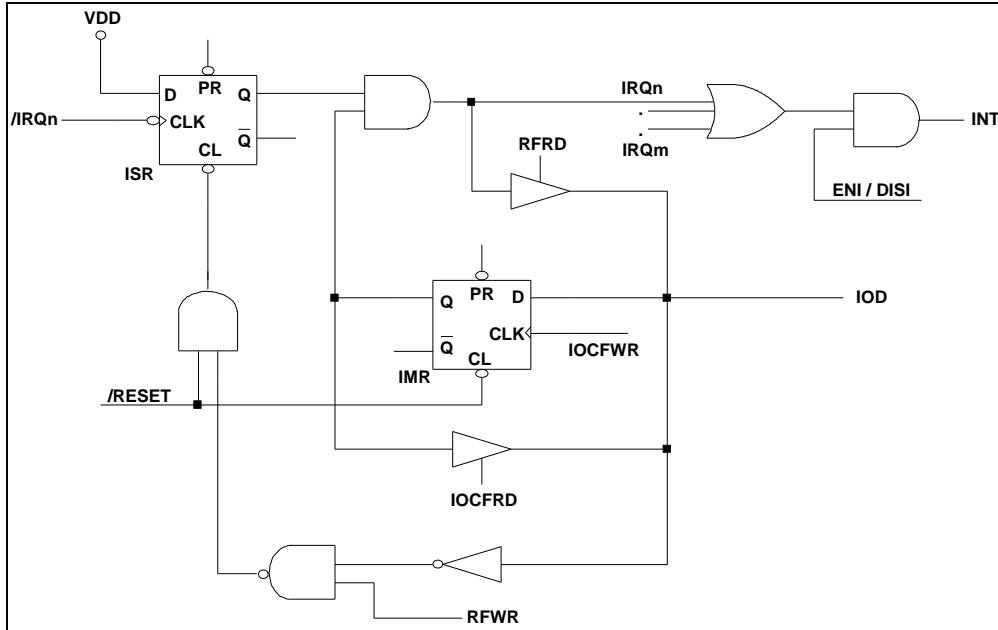

Figure 6-10 Interrupt Input Circuit Diagram

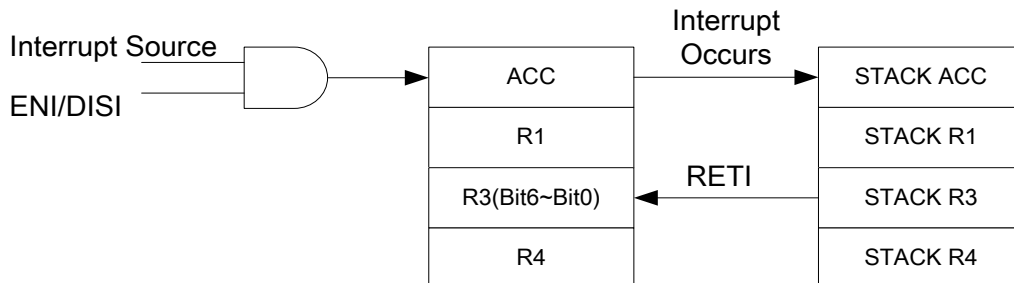

Figure 6-11 Interrupt Backup Diagram

6.6 A/D Converter

R_BANK	Address	Name	Bit 7	Bit 6	Bit 5	Bit 4	Bit 3	Bit 2	Bit 1	Bit 0
Bank 0	0x3E	ADCR1	CKR2	CKR1	CKR0	ADRUN	ADP	ADOM	SHS1	SHS0
			R/W	R/W	R/W	R/W	R/W	R/W	R/W	R/W
Bank 0	0x3F	ADCR2		VPIS2	ADIM	ADCMS	VPIS1	VPIS0	VREFP	
				R/W	R/W	R/W	R/W	R/W	R/W	
Bank 0	0x40	ADISR					ADIS3	ADIS2	ADIS1	ADIS0
							R/W	R/W	R/W	R/W
Bank 0	0x41	ADER1	ADE7	ADE6	ADE5	ADE4	ADE3	ADE2	ADE1	ADE0
			R/W	R/W	R/W	R/W	R/W	R/W	R/W	R/W
Bank 0	0x43	ADDL	ADD7	ADD6	ADD5	ADD4	ADD3	ADD2	ADD1	ADD0
			R	R	R	R	R	R	R	R
Bank 0	0x44	ADDH	ADD15	ADD14	ADD13	ADD12	ADD11	ADD10	ADD9	ADD8
			R	R	R	R	R	R	R	R
Bank 0	0x45	ADCVL	ADCD7	ADCD6	ADCD5	ADCD4	ADCD3	ADCD2	ADCD1	ADCD0
			R/W	R/W	R/W	R/W	R/W	R/W	R/W	R/W
Bank 0	0x46	ADCVH	ADCD15	ADCD14	ADCD13	ADCD12	ADCD11	ADCD10	ADCD9	ADCD8
			R/W	R/W	R/W	R/W	R/W	R/W	R/W	R/W
Bank 0	0x10	WUCR2				ADWK				
						R/W				
Bank 0	0x14	SFR1				ADSF				
						R/W				
Bank 0	0x1B	IMR1				ADIE				
						R/W				

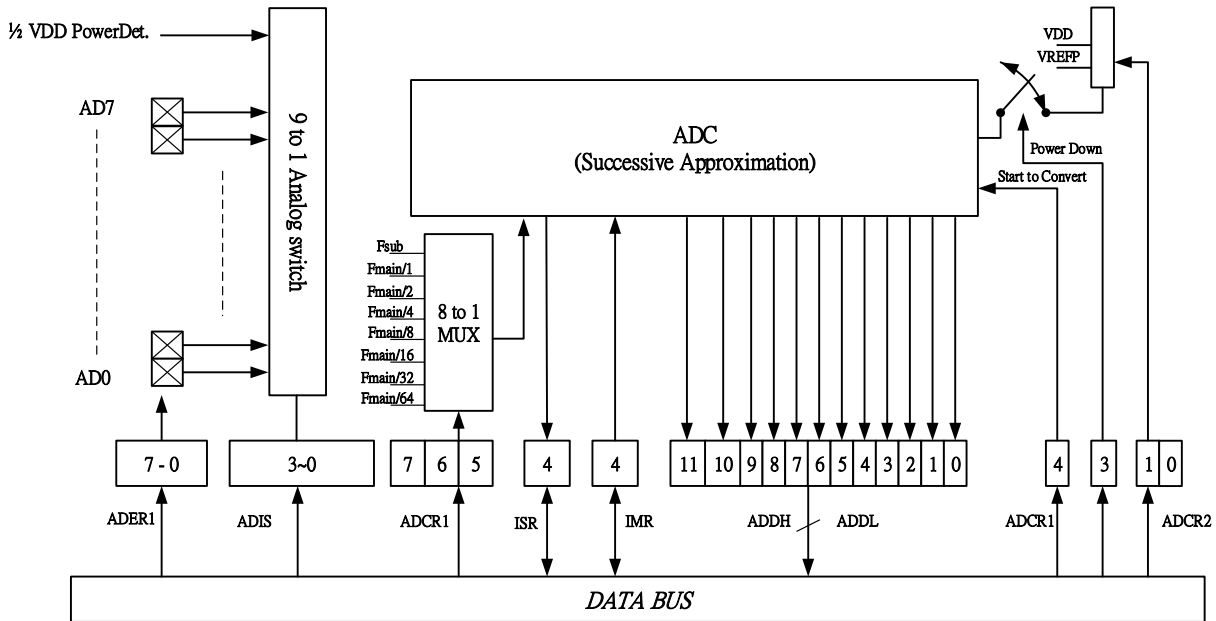

Figure 6-13 AD Converter

This is a 12-bit successive approximation register analog to digital converter (SAR ADC). There are two reference voltages for SAR ADC. The positive reference voltage can select internal AVDD, internal voltage sources or external input pin by setting the VREFP and VPIS [1:0] bits in ADCR2. Connecting to external positive reference voltage provides more accuracy than using internal AVDD.

6.6.1 ADC Data Register

When the AD conversion is completed, the result is loaded to the ADDH and ADDL and the ADSF is set if ADIE is enabled.

6.6.2 A/D Sampling Time

The accuracy, linearity, and speed of the successive approximation AD converter are dependent on the properties of the ADC. The source impedance and the internal sampling impedance directly affect the time required to charge the sample and hold capacitor. The application program controls the length of the sample time to meet the specified accuracy. Generally, the program should wait for 4 μ s for each kilo ohms of the analog source impedance and at least 4 μ s for the low-impedance source. The maximum recommended impedance for the analog source is 10K Ω at VDD = 5V. After the analog input channel is selected, this acquisition time must be done before AD conversion can be started.

6.6.3 A/D Conversion Time

CKR[2:0] select the conversion time (T_{CT}), in terms of instruction cycles. This allows the MCU to run at maximum frequency without sacrificing accuracy of AD conversion. For the EM88F752N, the conversion time per bit is about 0.5 μ s. The following table shows the relationship between T_{CT} and the maximum operating frequencies.

System Mode	CKR2~0	Clock Rate	Max. System Operation Frequency in 2.1~2.2V	Max. System Operation Frequency in 2.2~2.7V	Max. System Operation Frequency in 2.7~5V
Normal Mode	000	FMain/16	8 MHz	-	20 MHz
	001	FMain/8	4 MHz	8 MHz	16 MHz
	010	FMain/4	2 MHz	4 MHz	8 MHz
	011	FMain/2	1 MHz	2 MHz	4 MHz
	100	FMain/64	-	-	20 MHz
	101	FMain/32	-	-	20 MHz
	110	FMain/1	500 kHz	1 MHz	2 MHz
	111	FSub	Fs	Fs	Fs
Green Mode	xxx	FSub	Fs	Fs	Fs

NOTE

For the system operation frequency, it is necessary to refer to Table 10 of Section 6.12.

6.6.4 ADC Operation during Sleep Mode

In order to obtain a more accurate ADC value and reduce power consumption, the AD conversion remains operational during sleep mode. As the SLEP instruction is executed, all the MCU operations will stop except for the Oscillator, TCC, TC1~3, PWMA~B timers and AD conversion.

The AD Conversion is considered completed as determined by:

1. The ADRUN bit of the Bank 0-R3E register is cleared to “0”.
2. The ADSF bit of the Bank 0-R15 register is set to “1”.
3. The ADWK bit of the Bank 0-R10 register is set to “1”. Wakes up from ADC conversion (where it remains in operation during sleep mode).
4. Wakeup and execution of the next instruction if the ADIE bit of the Bank0-R1B is enabled and the “DISI” instruction is executed.
5. Wakeup and enters into Interrupt vector if the ADIE bit of the Bank0-R1B is enabled and the “ENI” instruction is executed.
6. Enters into an Interrupt vector if the ADIE bit of the Bank0-R1B is enabled and the “ENI” instruction is executed.

The results are fed into the ADDL and ADDH registers when the conversion is completed. If the ADWK is enabled, the device will wake up. Otherwise, the AD conversion will be shut-off, no matter what the status of the ADP bit is.

6.6.5 Programming Process/Considerations

Follow these steps to obtain data from the ADC:

1. Write to the bits (ADE[7:0]) on the Bank0-R41 (ADER1) register to define the characteristics of P50~P57 (digital I/O, analog channels)
2. Write to the Bank0-R3E(ADCR1) register to configure the AD module:
 - a) Select the ADC input channel (ADIS[3:0])
 - b) Define the AD conversion clock rate (CKR[2:0])
 - c) Select the VREFP input source of the ADC
 - d) Set the ADP bit to 1 to begin sampling
3. Set the ADWK bit, if the wake-up function is employed
4. Set the ADIE bit, if the interrupt function is employed
5. Write “ENI” instruction, if the interrupt function is employed
6. Set the ADRUN bit to 1
7. Write “SLEP” instruction or Polling.
8. Wait for wake-up or for the ADRUN bit to be cleared to “0” , status flag (ADSF) is set “1”, or ADC interrupt occurs.

9. Read the ADDL and ADDH conversion data registers. If the ADC input channel changes at this time, the ADDL and ADDH values can be cleared to '0'.
10. Clear the status flag (ADSF).
11. For next conversion, go to Step 1 or Step 2 as required. At least two T_{CT} is required before the next acquisition starts.

NOTE

In order to obtain accurate values, it is necessary to avoid any data transition on the I/O pins during AD conversion

6.6.6 Programming Process for Detecting Internal VDD

VDD is detected within the operation, as described in the previous section the difference is that before starting the ADC conversion, the first detection of VDD is ready. Therefore in Detecting VDD:

It should be noted that before starting the AD conversion operation, the channel has to be switched to 1/2VDD channel, the voltage divider is started, then AD can be converted. Several points to note is that, precise conversion values can be added in the VDD Pin capacitance, or more than twice the conversion, taking the average or the last few strokes data in order to increase the reliability of the data.

Note that usually before VDD is detected, do not switch the channel to 1/2VDD channel, as it has always been a DC current consumption, must be switched to another channel analog multiplexer, and it will be shut out of the resistor divider, which requires user attention.

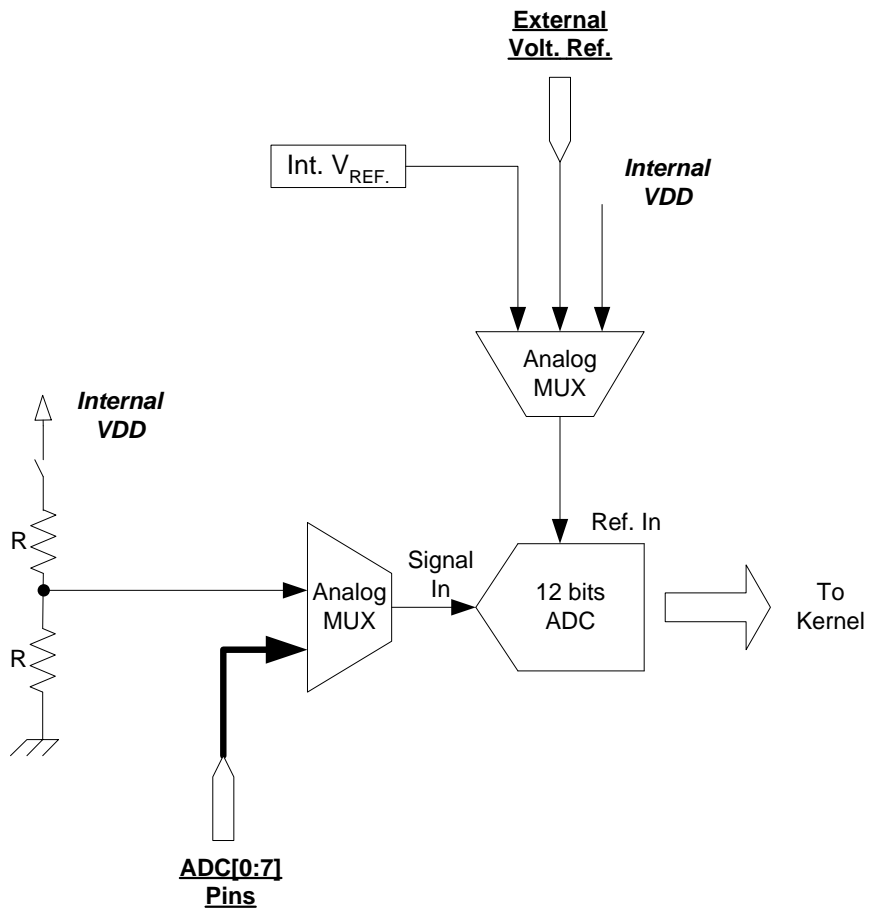

Figure 6-14 ADC and VDD Detection Block Diagram

6.7 Timer

There are three Timers in the EM88F752N. Timer2 and Timer3 are 8 bits up-counter. Timer 1 can be as one 8-bit up-counter or cascaded with Timer 2 as one 16-bit up-counter. If Timer 1 is used as 16-bit up-counter, the circuit resource of Timer2 would be used. At this time, Timer 2 cannot be used.

R_BANK	Address	Name	Bit 7	Bit 6	Bit 5	Bit 4	Bit 3	Bit 2	Bit 1	Bit 0
Bank 0	0x24	TC1CR1	TC1S	TC1RC	TC1SS1	TC1MOD	TC1FF	TC1OMS	TC1IS1	TC1IS0
			R/W	R/W	R/W	R/W	R	R/W	R/W	R/W
Bank 0	0x25	TC1CR2	TC1M2	TC1M1	TC1M0	TC1SS0	TC1CK3	TC1CK2	TC1CK1	TC1CK0
			R/W	R/W	R/W	R/W	R/W	R/W	R/W	R/W
Bank 0	0x26	TC1DA	TC1DA7	TC1DA6	TC1DA5	TC1DA4	TC1DA3	TC1DA2	TC1DA1	TC1DA0
			R/W	R/W	R/W	R/W	R/W	R/W	R/W	R/W
Bank 0	0x27	TC1DB	TC1DB7	TC1DB6	TC1DB5	TC1DB4	TC1DB3	TC1DB2	TC1DB1	TC1DB0
			R/W	R/W	R/W	R/W	R/W	R/W	R/W	R/W
Bank 0	0x28	TC2CR1	TC2S	TC2RC	TC2SS1		TC2FF	TC2OMS	TC2IS1	TC2IS0
			R/W	R/W	R/W		R	R/W	R/W	R/W
Bank 0	0x29	TC2CR2	TC2M2	TC2M1	TC2M0	TC2SS0	TC2CK3	TC2CK2	TC2CK1	TC2CK0
			R/W	R/W	R/W	R/W	R/W	R/W	R/W	R/W
Bank 0	0x3A	TC2DA	TC2DA7	TC2DA6	TC2DA5	TC2DA4	TC2DA3	TC2DA2	TC2DA1	TC2DA0
			R/W	R/W	R/W	R/W	R/W	R/W	R/W	R/W
Bank 0	0x3B	TC2DB	TC2DB7	TC2DB6	TC2DB5	TC2DB4	TC2DB3	TC2DB2	TC2DB1	TC2DB0
			R/W	R/W	R/W	R/W	R/W	R/W	R/W	R/W
Bank 0	0x3C	TC3CR1	TC3S	TC3RC	TC3SS1		TC3FF	TC3OMS	TC3IS1	TC3IS0
			R/W	R/W	R/W		R	R/W	R/W	R/W
Bank 0	0x3D	TC3CR2	TC3M2	TC3M1	TC3M0	TC3SS0	TC3CK3	TC3CK2	TC3CK1	TC3CK0
			R/W	R/W	R/W	R/W	R/W	R/W	R/W	R/W
Bank 0	0x3E	TC3DA	TC3DA7	TC3DA6	TC3DA5	TC3DA4	TC3DA3	TC3DA2	TC3DA1	TC3DA0
			R/W	R/W	R/W	R/W	R/W	R/W	R/W	R/W
Bank 0	0x3F	TC3DB	TC3DB7	TC3DB6	TC3DB5	TC3DB4	TC3DB3	TC3DB2	TC3DB1	TC3DB0
			R/W	R/W	R/W	R/W	R/W	R/W	R/W	R/W
Bank 0	0x15	SFR2						TC3DIF	TC2DIF	TC1DIF
								F	F	F
Bank 0	0x1C	IMR2						TC3DIE	TC2DIE	TC1DIE
								R/W	R/W	R/W

6.7.1 Timer/Counter Mode

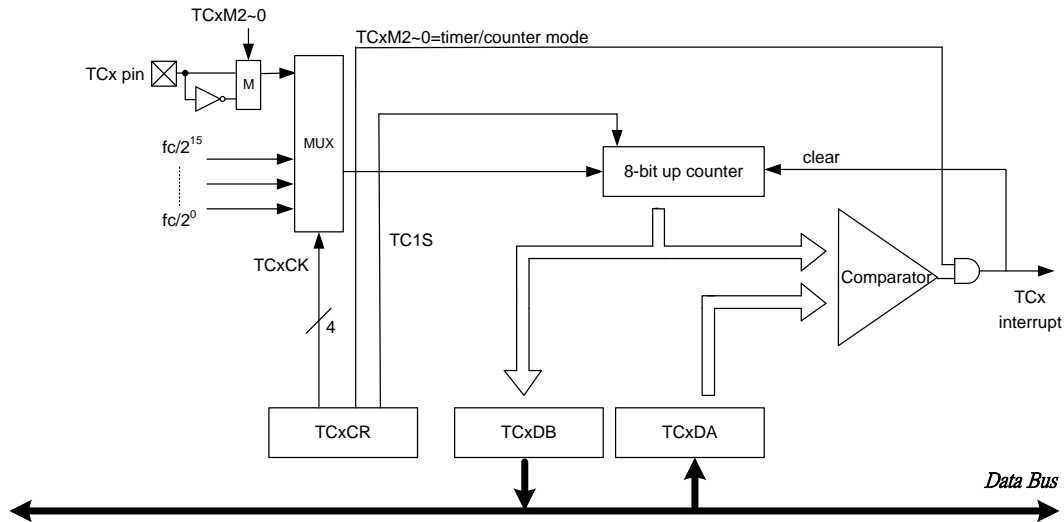

Figure 6-15 Timer/Counter Mode

In Timer/Counter mode, counting up is performed using internal clock or TCx pin. When the contents of up-counter are matched the TCxDA, then interrupt is generated and counter is cleared. Counting up resumes after the counter is cleared. The current contents of up-counter are loaded into TCxDB by setting TCxRC to "1".

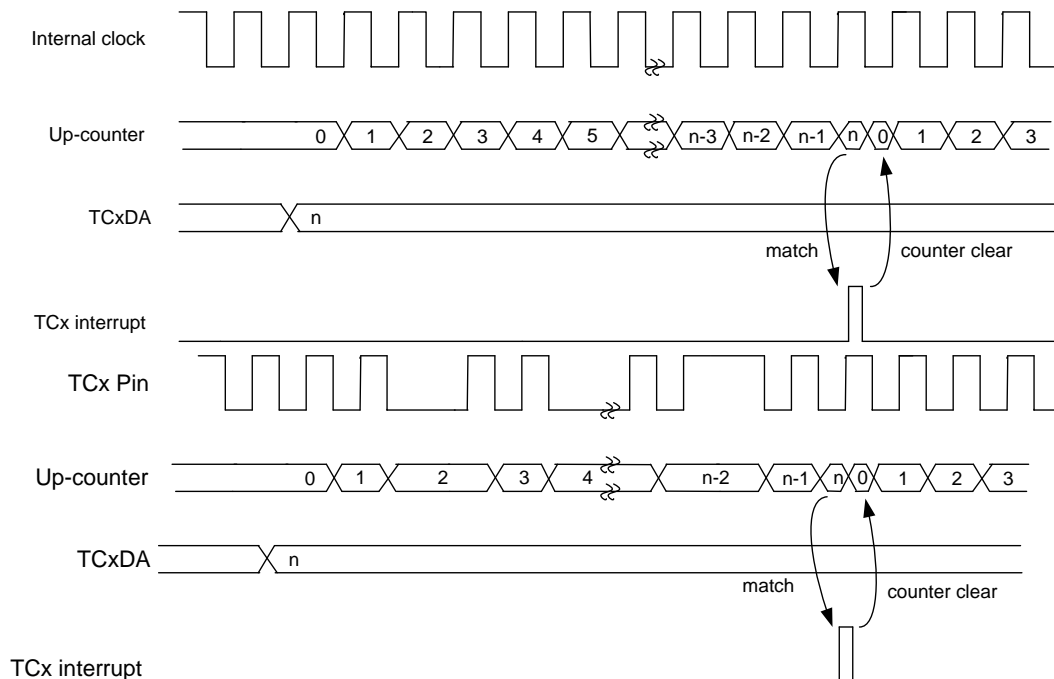

Figure 6-16 Timer/Counter Mode Waveform

6.8.2 Window Mode

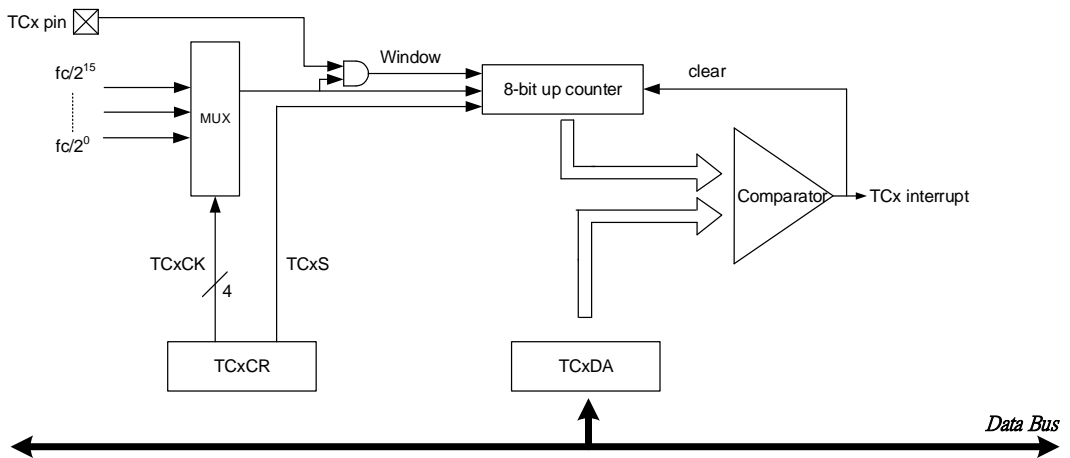

Figure 6-17 Window Mode

In Window mode, counting up is performed on rising edge of the pulse that is logical AND of an internal clock and the TCx pin (window pulse). When the contents of up-counter are matched the TCxDA, then interrupt is generated and counter is cleared. The frequency (window pulse) must be slower than the selected internal clock.

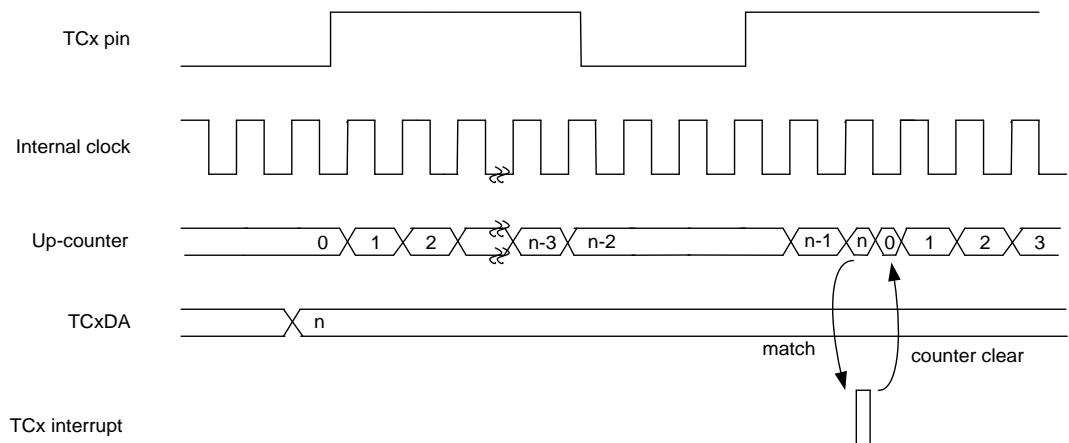

Figure 6-18 Window Mode Waveform

6.7.3 Capture Mode

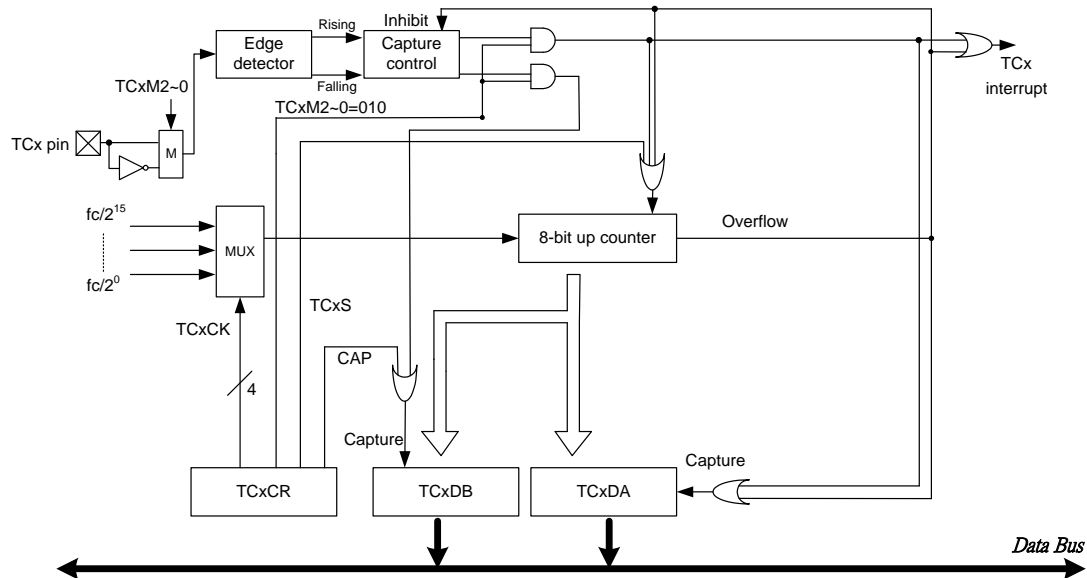

Figure 6-19 Capture Mode

In Capture mode, the pulse width, period and duty of the TCx input pin are being measured in this mode, which can be used to decoding the remote control signal. The counter is free running by the internal clock. On the rising (falling) edge of TCx pin, the contents of counter is loaded into TCxDA, then the counter is cleared and interrupt is generated. On the falling (rising) edge of TCx pin, the contents of counter are loaded into TCxDB. At this time, the counter is still counting. Once the next rising edge of TCx pin triggers, the contents of counter are loaded into TCxDA, the counter is cleared and interrupt is generated again. If overflow before the edge is detected, the FFH is loaded into TCxDA and the overflow interrupt is generated. During interrupt processing, it can determine whether or not there is an overflow by checking if the TCxDA value is FFH. After an interrupt (capture to TCxDA or overflow detection) is generated, capture and overflow detection are halted until TCxDA is read out.

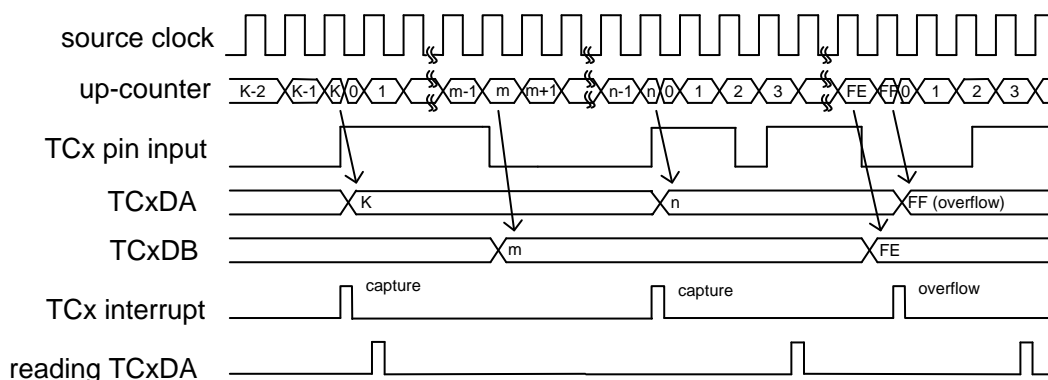

Figure 6-20 Capture Mode Waveform

6.7.4 Programmable Divider Output Mode and Pulse Width Modulation Mode

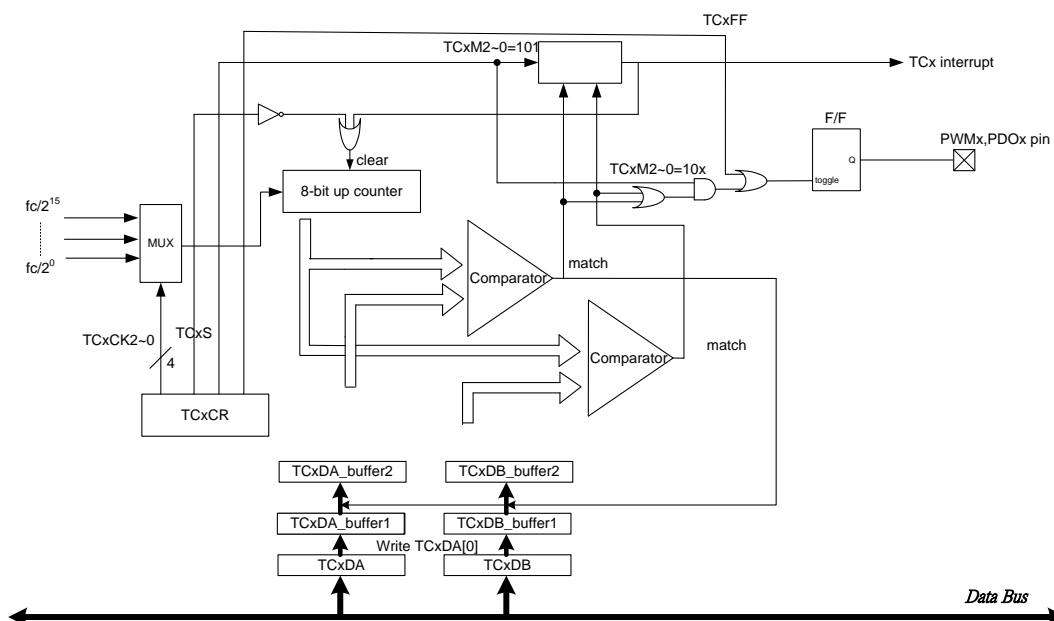

Figure 6-21 PWM/PDO Mode

6.7.5 PDO

In Programmable Divider Output (PDO) mode, counting up is performed using internal clock. The contents of TCxDA are compared with the contents of up-counter. The F/F output is toggled and the counter is cleared each time a match is found. The F/F output is inverted and output to PDO pin. This mode can generate 50% duty pulse output. The PDO pin is initialized to “0” during reset. A TCx interrupt is generated each time the PDO output is toggled.

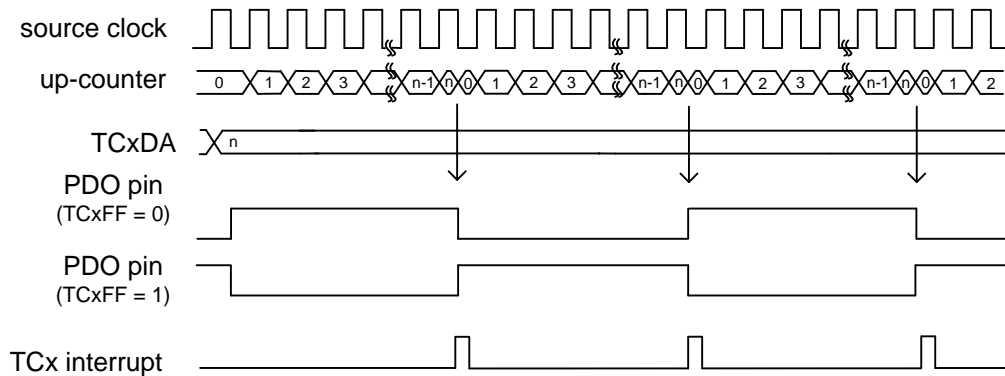

Figure 6-22 PDO Mode Waveform

6.7.6 PWM

In Pulse Width Modulation (PWM) Output mode, counting up is performed using the internal clock with prescaler. The Duty of PWMx control by TCxDB, and the period of PWMx control by TCxDA. The pulse at the PWMx pin is held to high level as long as TCxS=1 or Timer x matches TCxDA, while the pulse is held to low level as long as timer matches TCxDB. Once TCxFF is set to 1, the signal of PWMx is inverted. A TCx interrupt is generated and defined by TCxIS. On the other hand, the TCxDA and TCxDB can be written anytime, but the data of TCxDA and TCxDB are latched only at writing TCxDA[0]. Therefore, the new duty and new period of PWM appear at the PMW pin at the last period-match.

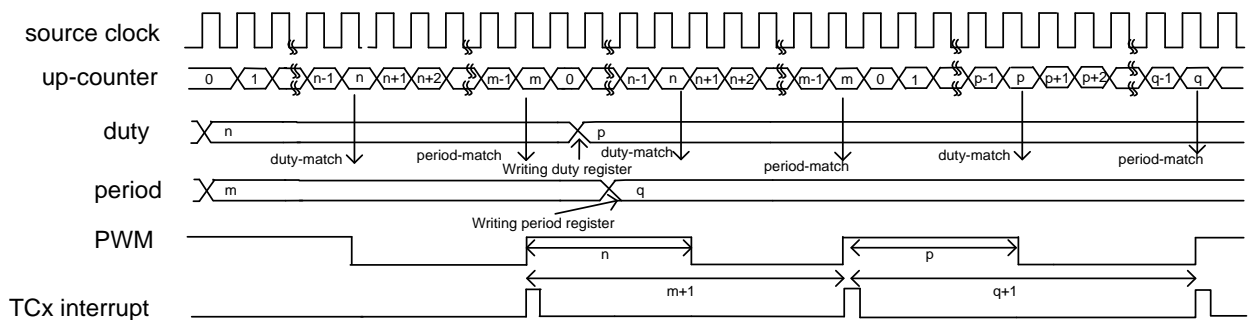

Figure 6-23 PWM Mode Waveform

6.7.7 Buzzer Mode

TCx pin output the clock after dividing frequency

6.8 PWM

R_BAN	Address	Name	Bit 7	Bit 6	Bit 5	Bit 4	Bit 3	Bit 2	Bit 1	Bit 0
Bank 0	0x16	SFR3					PWMBP SF	PWMBD SF	PWMAP SF	PWMAD SF
							F	F	F	F
Bank 0	0x1D	IMR3					PWMBP IE	PWMBD IE	PWMAP IE	PWMAD IE
							R/W	R/W	R/W	R/W
Bank 1	0x14	DeadTCR					DEAD TBE	DEAD TAE	DEAD TP1	DEAD TP0
							R/W	R/W	R/W	R/W
Bank 1	0x15	DeadTR	DEADTR[7:0]							
			R/W	R/W	R/W	R/W	R/W	R/W	R/W	R/W
Bank 1	0x16	PWMSCR				DEADS			PWMBS	PWMAS
						R/W			R/W	R/W
Bank 1	0x17	PWMA CR	PWMAE	IPWMAE	PWMAA	IPWMAA	TAEN	TAP2	TAP1	TAP0
			R/W	R/W	R/W	R/W	R/W	R/W	R/W	R/W
Bank 1	0x18	PRDAL	PRDA[7:0]							
			R/W	R/W	R/W	R/W	R/W	R/W	R/W	R/W
Bank 1	0x19	PRDAH							PRDA[9:8]	
									R/W	R/W
Bank 1	0x1A	DTAL	DTA[7:0]							
			R/W	R/W	R/W	R/W	R/W	R/W	R/W	R/W
Bank 1	0x1B	DTAH							DTA[9:8]	
									R/W	R/W
Bank 1	0x1C	TMRAL	TMRA[7:0]							
			R	R	R	R	R	R	R	R
Bank 1	0x1D	TMRAH							TMRA[9:8]	
									R	R
Bank 1	0x1E	PWMB CRR	PWMBE	IPWMBE	PWMB A	IPWMB A	TBEN	TBP2	TBP1	TBP0
			R/W	R/W	R/W	R/W	R/W	R/W	R/W	R/W
Bank 1	0x1F	PRDBL	PRDB[7:0]							
			R/W	R/W	R/W	R/W	R/W	R/W	R/W	R/W
Bank 1	0x20	PRDBH							PRDB[9:8]	
									R/W	R/W
Bank 1	0x21	DTBL	DTB[7:0]							
			R/W	R/W	R/W	R/W	R/W	R/W	R/W	R/W
Bank 1	0x22	DTBH							DTB[9:8]	
									R/W	R/W
Bank 1	0x23	TMRBL	TMRB7							
			R	R	R	R	R	R	R	R
Bank 1	0x24	TMRBH							TMRB[9:8]	
									R	R

For example, set period and duty cycle (Period > Duty), PWMXE=1/0 and IPWME=0/1, PWMXA = 1/0, and finally set TXEN = 1. The following figures show PWM output timing according to different PWMXA and IPWME settings.

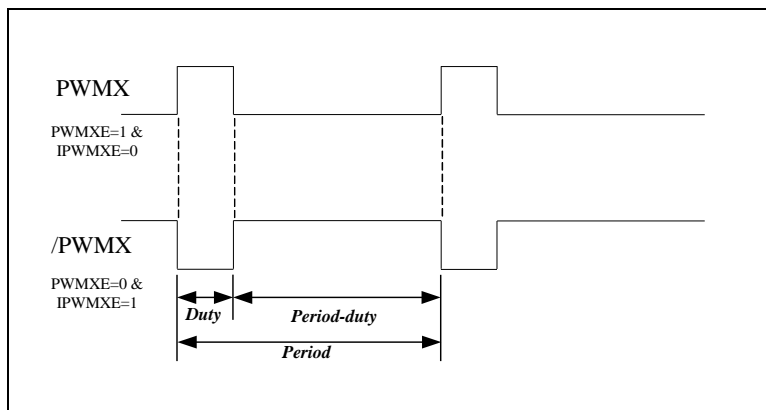

Figure 6-25 PWM Output Timing (PWMXA=0 and IPWME=0)

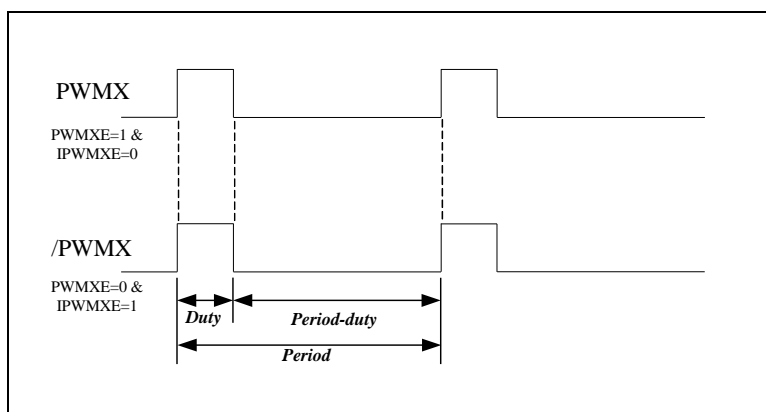

Figure 6-26 PWM Output Timing (PWMXA=0 and IPWME=1)

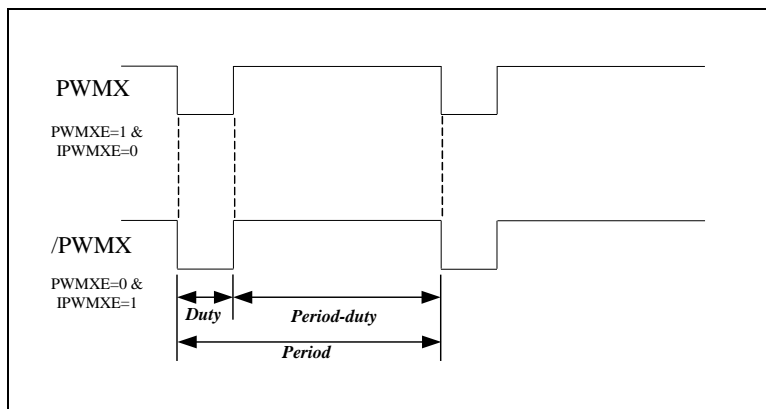

Figure 6-27 PWM Output Timing (PWMXA=1 and IPWME=0)

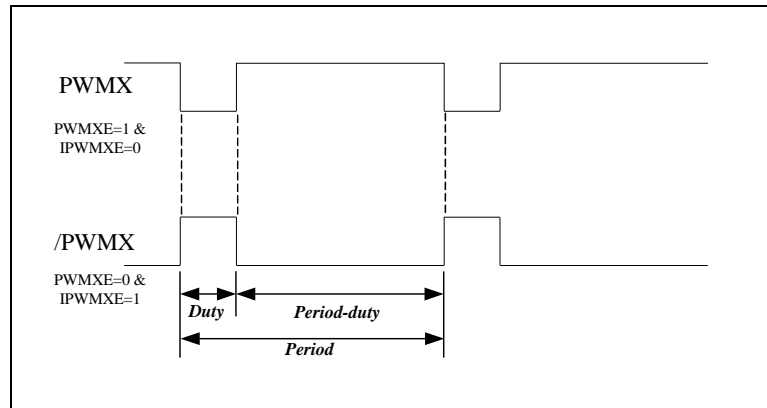

Figure 6-28 PWM Output Timing (PWMXA=1 and IPWMA=1)

6.8.2 Increment Timer Counter (TMRX: TMRAL/TMRAL, TMRBH/TMRBL)

TMRX are 10-bit clock counters with programmable prescaler. They are designed for the PWM module as baud rate clock generators. TMR can be read only. If employed, they can be turned off for power saving by setting the PWMACR [TAEN], or PWMBCR [TBEN] to 0.

TMRA, TMRB, and are internally designed and cannot be set.

6.8.3 PWM Time Period (PRDX: PRDAL/H, PRDBL/H)

The PWM period is 10-bit resolution. The PWM time period is defined by writing to the PRDX register. When TMRX is equal to PRDX, the following events occur on the next increment cycle:

- TMRX is cleared
- The PWMX pin is set to 1

NOTE

The PWM output will not be set, if the duty cycle is 0

- The PWMXIF pin is set to 1

The following formula describes how to calculate the PWM time period:

$$Period = (PRDX + 1) \times \left(\frac{1}{F_{OSC}} \right) \times (TMRX \text{ prescale value})$$

Example:

PRDX = 49; Fosc = 4 MHz; TMRX (0, 0, 0) = 1 : 1,

Then

$$Period = (49+1) \times \left(\frac{1}{4M} \right) \times 1 = 12.5\mu s$$

6.8.4 PWM Duty Cycle (DTX: DTAH/DTAL or DTBH/DTBL)

The PWM duty cycle is defined by writing to the DTX register, and is latched from DTX to DLX while TMRX is cleared. When DLX is equal to TMRX, the PWMX pin is cleared. DTX can be loaded anytime. However, it cannot be latched into DLX until the current value of DLX is equal to TMRX.

The following formula describes how to calculate the PWM duty cycle:

$$Duty\ cycle = (DTX) \times \left(\frac{1}{F_{osc}} \right) \times (TMRX\ prescale\ value)$$

Example:

DTX = 10; Fosc = 4 MHz; TMRX (0, 0, 0) = 1 : 1,

Then

$$Duty\ cycle = (10) \times \left(\frac{1}{4M} \right) \times 1 = 2.5\mu s$$

6.8.5 Dual PWM function

It consists of a complementary PWM (i.e. PWMX and /PWMX), one outputs PWM signal and the other outputs inverted PWM signal, It can output any pulse width signal you want by programming relative control registers.

The dead time mode is supported. It means that the complementary PWM signals can be controlled to get a time interval that the complementary PWM signals will not be intersected.

The following Figures 6-29 ~ 30 show the dual PWM output waveform.

Disable dead time control ($DEADTXE = 0$). Set period and duty cycle (period > duty). Set $PWMXE$ and $IPWMXE = 1$, $PWMXA = 0/1$, $IPWMA = 0/1$, and finally set $TXEN = 1$.

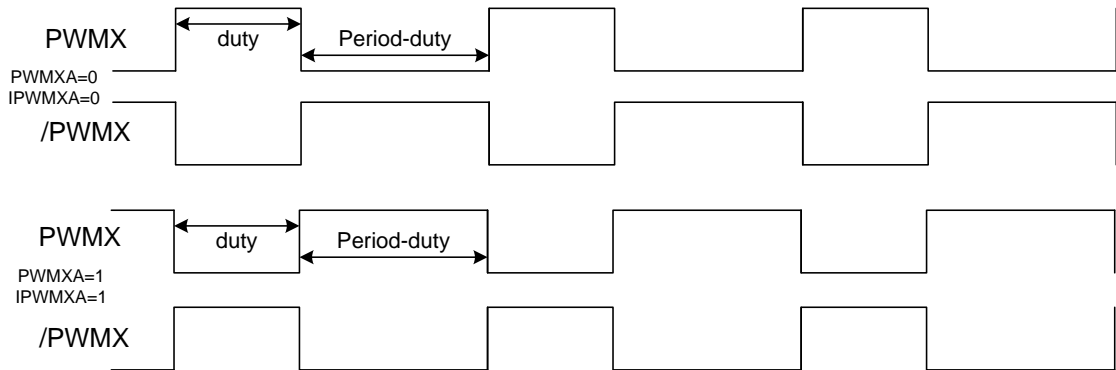

Figure 6-29 Dual PWMX Output Waveform ($DEADTXE = 0$)

Set dead time > 0 (set dead time prescaler if required). Enable dead time control ($DEADTXE = 1$). Set period and duty cycle (period > duty). Set $PWMXE$ and $IPWME = 1$, $PWMXA = 0$, $IPWMA = 0$, and finally set $TXEN = 1$. For the loading new duty, period, and deadtime value at run time, following subchapter “PWM Programming Process/Steps” makes such descriptions.

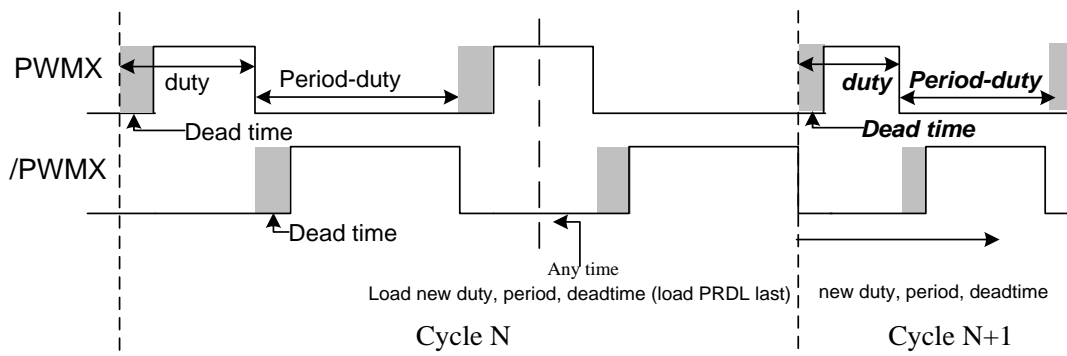

Figure 6-30 Dual PWMX Output Waveform ($DEADTXE = 1$, Dead Time > 0)

6.9 I2C Function

R_BANK	Address	Name	Bit 7	Bit 6	Bit 5	Bit 4	Bit 3	Bit 2	Bit 1	Bit 0
Bank 0	0x30	I2CCR1	Strobe/Pend	IMS	ISS	STOP	SAR_EMPTY	ACK	FULL	EMPTY
			R/W	R/W	R/W	R/W	R/W	R/W	R/W	R/W
Bank 0	0x31	I2CCR2	I2CBF	GCEN		BBF	I2CTS1	I2CTS0		I2CEN
			R	R/W		R	R/W	R/W		R/W
Bank 0	0x32	I2CSA	SA6	SA5	SA4	SA3	SA2	SA1	SA0	IRW
			R/W	R/W	R/W	R/W	R/W	R/W	R/W	R/W
Bank 0	0x33	I2CDB	DB7	DB6	DB5	DB4	DB3	DB2	DB1	DB0
			R/W	R/W	R/W	R/W	R/W	R/W	R/W	R/W
Bank 0	0x34	I2CDAL	DA7	DA6	DA5	DA4	DA3	DA2	DA1	DA0
			R/W	R/W	R/W	R/W	R/W	R/W	R/W	R/W
Bank 0	0x35	I2CDAH							DA9	DA8
									R/W	R/W
Bank 0	0x17	SFR4						I2CSTPIF	I2CRSF	I2CTSIF
								R/W	R/W	R/W
Bank 0	0x1E	IMR4						I2CSTPIE	I2CRIE	I2CTIE
								R/W	R/W	R/W

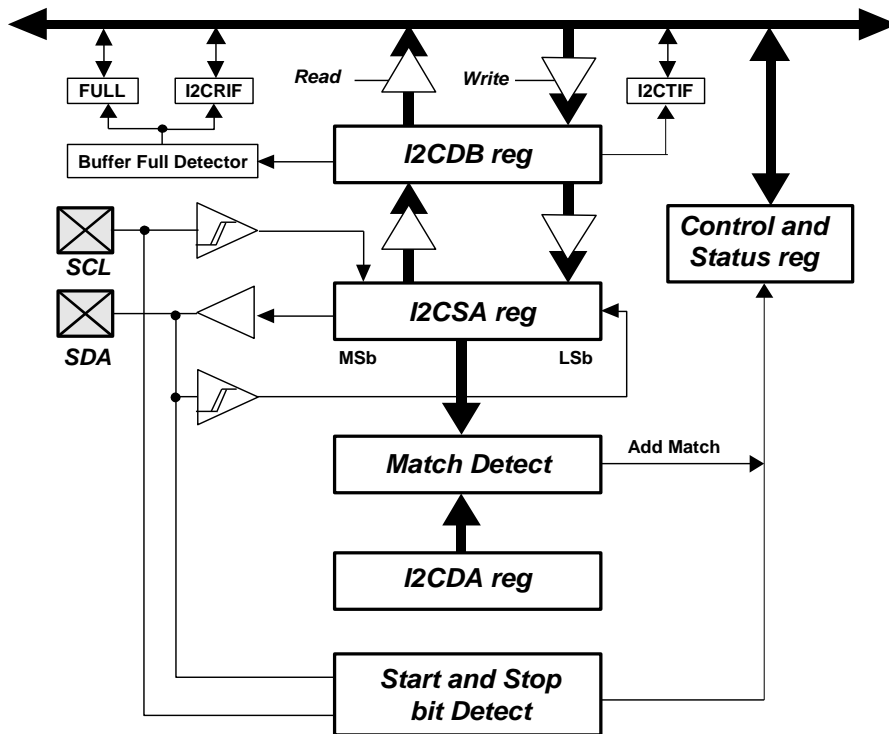

Figure 6-31 I2C Block Diagram

The EM88F752N supports a bidirectional, 2-wire bus, 7/10-bit addressing and data transmission protocol. A device that sends data onto the bus is defined as a transmitter, while a device receiving data is defined as a receiver. The bus has to be controlled by a master device which generates the Serial Clock (SCL), controls the bus access and generates the Start and Stop conditions. Both master and slave can operate as transmitter or receiver, but the master device determines which mode is activated.

Both SDA and SCL are bi-directional lines, connected to a positive supply voltage via a pull-up resistor. When the bus is free, both lines are HIGH. The output stages of devices connected to the bus must have an open-drain or open-collector to perform the wired-AND function. Data on the I2C-bus can be transferred at rates of up to 100 kbps in the Standard-mode or up to 400 kbps in the Fast-mode.

The data on the SDA line must be stable during the HIGH period of the clock. The HIGH or LOW state of the data line can only change when the clock signal on the SCL line is LOW.

I2C interrupt occurs as shown below:

Condition	Master/Slave	Transmit Address	Transmit Data	Stop
Master-transmitter transmits to slave-receiver	Master	Transmit interrupt	Transmit interrupt	Stop interrupt
	Slave	Receive interrupt	Receive interrupt	Stop interrupt
Master receiver read slave-transmitter	Master	Transmit interrupt	Receive interrupt	Stop interrupt
	Slave	Transmit interrupt	Transmit interrupt	Stop interrupt

Within the procedure of the I2C bus, unique situations arise which are defined as START (S) and STOP (P) conditions.

A HIGH to LOW transition on the SDA line while SCL is HIGH is one such unique case. This situation indicates a START condition.

A LOW to HIGH transition on the SDA line while SCL is HIGH defines a STOP condition.

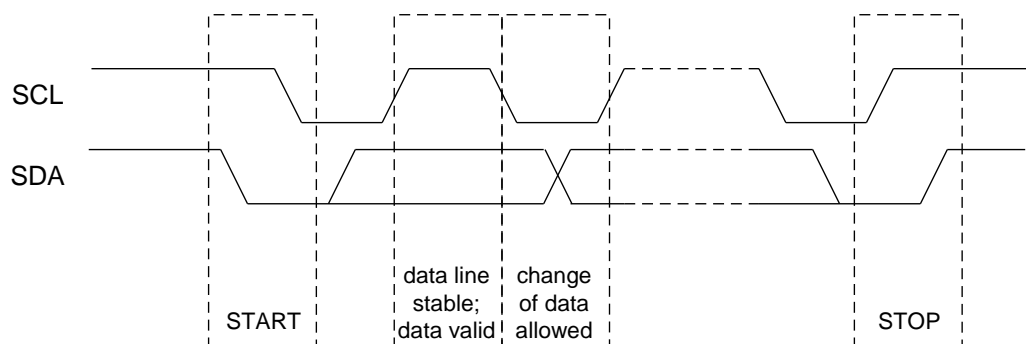

Figure 6-32 I2C Transfer Condition

6.9.1 7-Bit Slave Address

Master-transmitter transmits to slave-receiver. The transfer direction is not changed.

Master reads slave immediately after first byte. At the moment of the first acknowledge, the master-transmitter becomes a master-receiver and the slave-receiver becomes a slave-transmitter. This first acknowledge is still generated by the slave. The STOP condition is generated by the master, which has previously sent a not-acknowledge (/A).

The difference between master transmitter with master receiver is only in R/W bit, if the R/W bit were "0", the master device would be transmitter; the other way, the master device would be receiver. The master transmitter is described by the figure 6-33 "7-Bit slave address in Master-transmitter transmits to slave-receiver", and the master receiver is described by figure 6-34 "7-Bit slave address in Master-receiver read slave-transmitter".

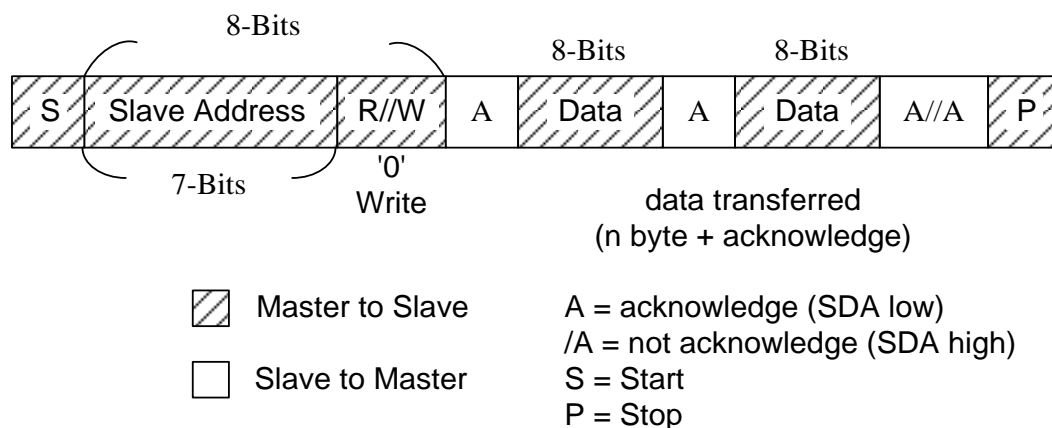

Figure 6-33-7-Bit Slave Address in Master-transmitter transmits to slave-receiver

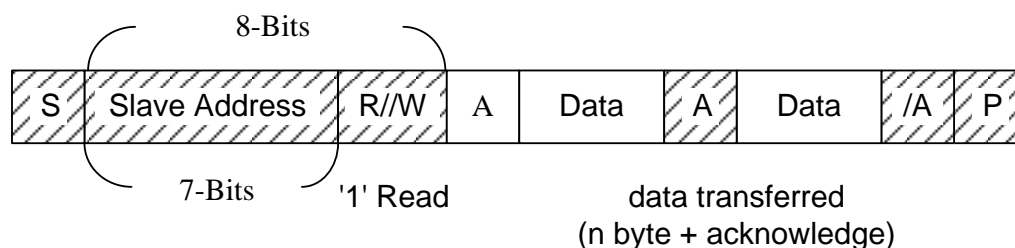

Figure 6-34-7-Bit Slave Address in Master receiver read slave-transmitter

6.9.2 10-Bit Slave Address

In 10-bit slave address mode, using 10 bits for addressing exploits the reserved combination 11110XX for the first seven bits of the first byte following a START(S) or repeated START (Sr) condition. The first seven bits of the first byte are the combination 11110XX of which the last two bits (XX) are the two most-significant bits of the 10-bits address. If the R/W bit were “0”, the second byte after acknowledge would be the eight address bits of 10-bits slave address; in the other way, the second byte would just only be the next transmitted data from a slave to master device. The first bytes 11110XX can be transmitted using the slave address register (I2CSA), and the second bytes XXXXXXXX can be transmitted using the data buffer (I2CDB).

There are few kinds of different formats explained in Figure 6-35~ Figure 6-39 in the 10-bit slave address mode. The possible data transfer formats are:

- **Master-transmitter transmits to slave-receiver with a 10-bit slave address**

When the slave have received the first byte after START bit from master, each slave devices will compare the seven bits of the first byte (11110XX) with their own address. As for the eighth bit, R/W, if the R/W bit were “0”, the slave would return the acknowledge (A1) and it is possible for more than one slave device to return it. Then all slave device will continue to compare the second address (XXXXXXXX), if the slave device have matched, only one slave device will return acknowledge. The matching slave device will remain addressed by the master until it receives the STOP condition or a repeated START condition followed by the different slave address.

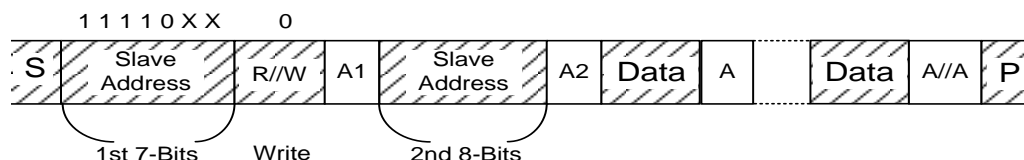

Figure 6-35 Master-transmitter transmits to slave-receiver with a 10-bit slave address

- **Master-receiver read slave-transmitter with a 10-bit slave address**

Up to and including acknowledge Bit A2, the procedure is the same as that described for master-transmitter addressing a slave receiver. After the acknowledge A2, a repeated START condition (Sr) followed by seven bits slave address (11110XX) but the eighth bit R/W is “1”, the addressed slave device will return the acknowledge A3. If the repeated START(Sr) condition and the seven bits of first byte(11110XX) received by slave device, all the slave device would compare with their own address and test the eighth R/W, but none of all slave device return the acknowledge because R/W=1.

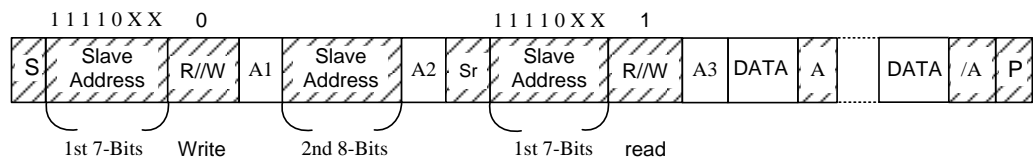

Figure 6-36 Master-receiver read slave-transmitter with a 10-bit slave address

- Master addresses a slave with 10-Bit addresses transmits and receives data in the same slave device.

At first, the transmitter procedure is the same as the section of the “Master-transmitter transmits to slave-receiver with a 10-bit slave address”, then the master device can start to transmit the data to slave device. If the slave device has received an acknowledge or none acknowledge which were followed by repeat START (Sr) and repeat the procedure of the section of “Master-receiver read slave-transmitter with a 10-bit slave address”.

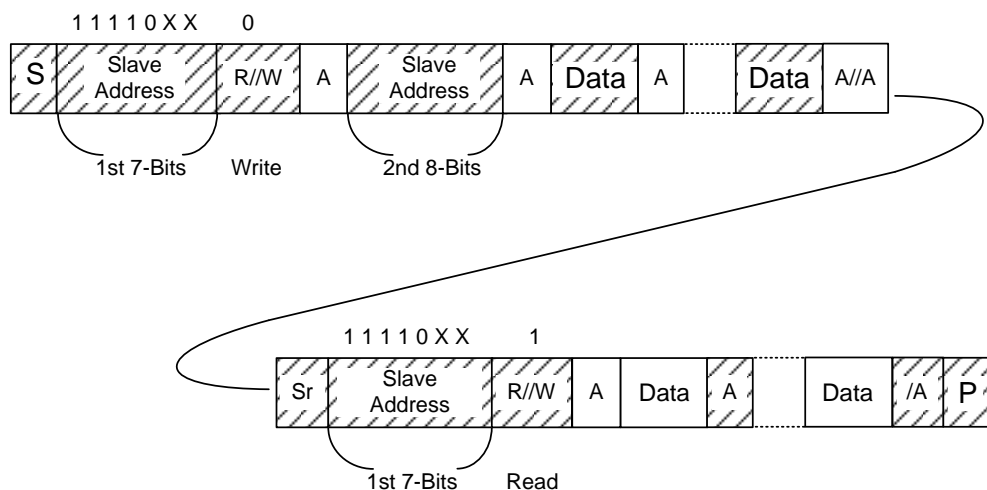

Figure 6-37 Master addresses a slave with 10-bit addresses transmits and receives data in the same slave device

- Master device transmit data to two or more than two slave device

The section of “Master-transmitter transmits to slave-receiver with a 10-bit slave address” describes the procedure of how to transmit the data to slave device, If the master device has finished the transmittal and wants to transmit the data to another device, the master would need to address the new slave device. The address procedure is described in a section of the “Master-transmitter transmits to slave-receiver with a 10-bit slave address”. If the master device wants to transmit the data in 7-bit slave address mode and transmit the data in 10-bit slave address mode in the serial transfer, after the START or repeat START conditions, a 7-bit and 10-bit address could be transmitted. Figure 6-38~6-39 shows how to transmit the data in 7-bit and 10-bit address mode in serial transfer.

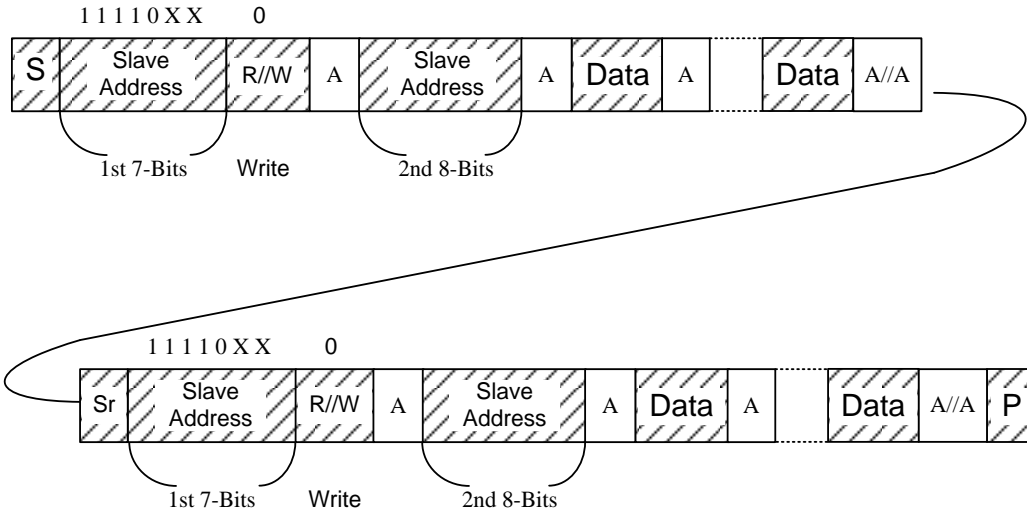

Figure 6-38 Transmit one more device with a 10-bit Slave Address

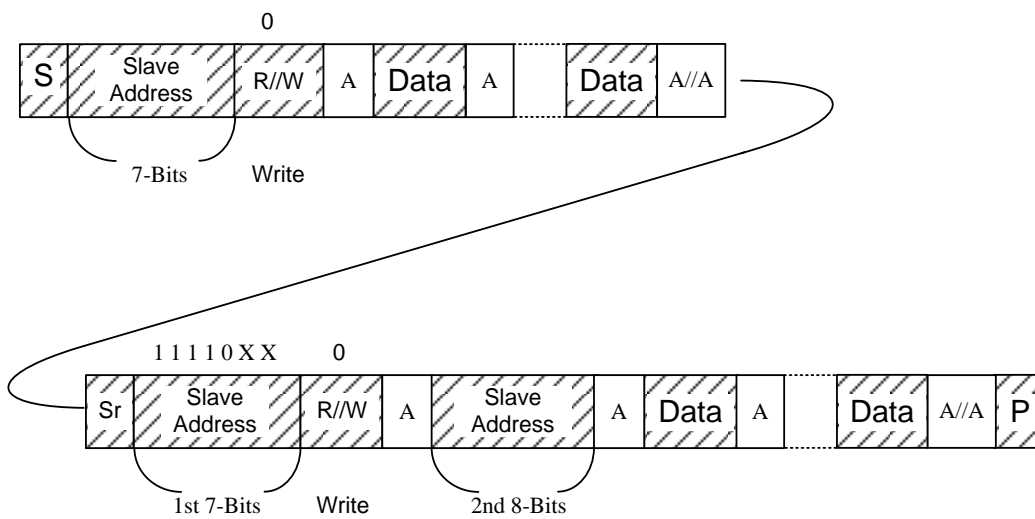

Figure 6-39 7-bit and 10-bit Slave Address Mode

6.9.3 Master Mode

In transmitting (receiving) serial data, the I2C operates as follows:

1. Set I2CTS1~0, and ISS bits to select I2C transmit clock source.
2. Set I2CEN and IMS bits to enable I2C master function.
3. Write slave address into the I2CSA register and IRW bit to select read or write.
4. Set strobe bit will start transmit and then Check I2CTSFS (I2CTSFS) bit.
5. Write 1st data into the I2CDB register, set strobe bit and Check I2CTSFS (I2CRSF) bit.
6. Write 2nd data into the I2CDB register, set strobe bit, STOP bit and Check I2CTSFS (I2CRSF) bit.

6.9.4 Slave Mode

In receiving (transmitting) serial data, the I2C operates as follows:

1. Set I2CTS1~0 and ISS bits to select I2C transmit clock source.
2. Set I2CEN and IMS bits to enable I2C slave function.
3. Write device address into the I2CDA register.
4. Check I2CRSF (I2CTSFS) bit, read I2CDB register (address) and then clear Pend bit.
5. Check I2CRSF (I2CTSFS) bit, read I2CDB register (1st data) and then clear Pend bit.
6. Check I2CRSF (I2CTSFS) bit, read I2CDB register (2st data) and then clear Pend bit.
7. Check I2CSTPSF bit, end transmission.

6.10 Enhance Protect

R_BANK	Address	Name	Bit 7	Bit 6	Bit 5	Bit 4	Bit 3	Bit 2	Bit 1	Bit 0
Bank 2	0x47	LOCKPR	LOCKPR7	LOCKPR6	LOCKPR5	LOCKPR4	LOCKPR3	LOCKPR2	LOCKPR1	LOCKPR0
			R/W	R/W	R/W	R/W	R/W	R/W	R/W	R/W
Bank 2	0x48	LOCKCR	LOCKEN							
			R/W							

The EM88F752N supports a protect function that prevents the source code from overwriting or reading. When the instruction TBRDA/TBRD/TBWR is executed at a protect area, it can write or read all flash ROM. On the other hand, when the instruction TBRDA/TBRD/TBWR is executed at an unprotect area, it can only write or read the ROM in unprotect area.

6.10.1 Enhance Protect Programming

The Enhance Protect operates as follows:

1. Set LOCKEN.
2. Write 0xC5 into FLKR.
3. Write LOCKPR to set protect range.

*Instruction "TBRDA/TBRD/TBWR" cannot be written at the end of protect area

*The basic unit of LOCKPR is 128 words.

*When using the TBWR instruction, the code option "TBWEN" must be enabled.

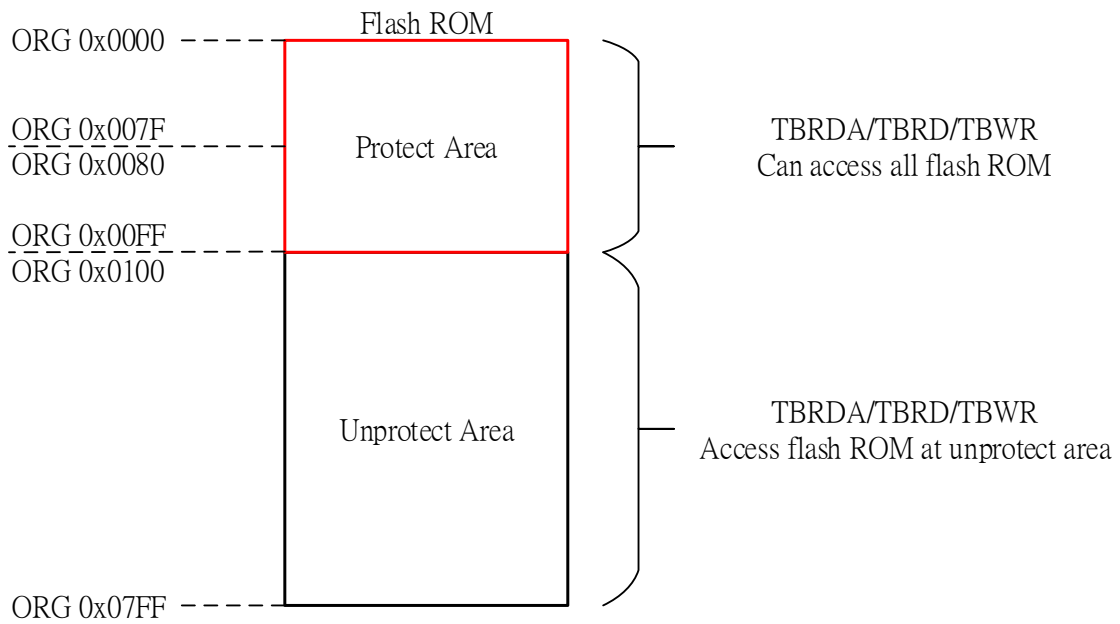

Figure 6-40 Example of Enhance Protect Function (LOCKPR=0x08)

6.11 In Application Programming

R_BANK	Address	Name	Bit 7	Bit 6	Bit 5	Bit 4	Bit 3	Bit 2	Bit 1	Bit 0
Bank 1	0x4D	TBWCR								IAPEN R/W
Bank 1	0x4E	TBWAL	TBWA[7] R/W	TBWA[6] R/W	TBWA[5] R/W	TBWA[4] R	TBWA[3] R	TBWA[2] R	TBWA[1] R	TBWA[0] R
Bank 1	0x4F	TBWAH	0	0	0	0	TBWA[11] R/W	TBWA[10] R/W	TBWA[9] R/W	TBWA[8] R/W

The EM88F702N supports In Application Programming, it can copy data from ram to rom and overwrite 32-word flash rom.

6.11.1 In Application Programming

The IAP operates as follows:

1. Set Code Option Word 2[TBWEN]
2. Move data you want to save in flash into RAM.
3. Set TBWAH/ TBWAL register according to programming address.
4. Enable IAP mode by setting TBWCR[IAPEN]
5. Write 0xB4 to FLKR register
6. Execute TBWR instruction
7. Then data will be written to ROM

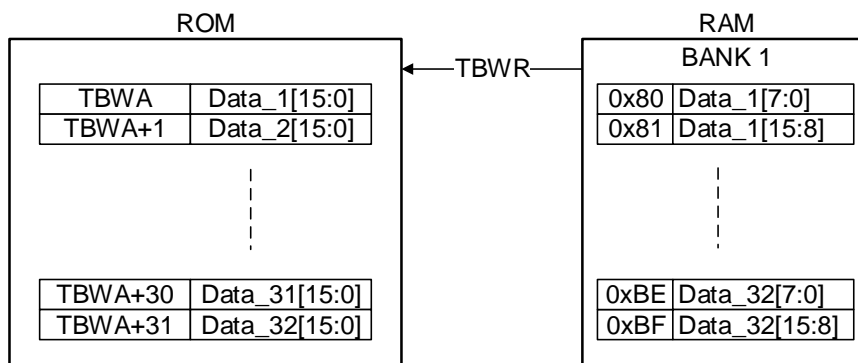

Figure 6-44 In Application Programming

6.12 Low Voltage Detector

In the situation where power source is unstable, such as external power noise interference or EMS test condition, the power will vibrate fiercely. During the time, V_{dd} is unsettled and possibly fell below working voltage.

EM88F752N supports LVD module for voltage detection, when LVD is enabled by setting LVDEN, the current consumption will increase about 100uA.

6.12.1 LVD

The following steps are needed to setup the LVD function:

1. Set Code the Bank1 R49 LVDCR[LVDEN] to enable the LVD function.
2. Use the Bank1 R49 LVDCR[LVDS1:LVDS0] to decide the LVD voltage detection level.
3. Set the Bank1 R49 LVDCR[LVDEN] to enable the LVD function.
4. Wait for low voltage to occur and lead to LVD interrupt.

During Sleep mode, the LVD module continues to operate. If the device voltage drops slowly and crosses the detection point. The LVDSF bit will be set and the device will not wake-up from Sleep mode. Until EM88F752N is woken up by another wake up source,, the LVD interrupt flag will remain in the prior status.

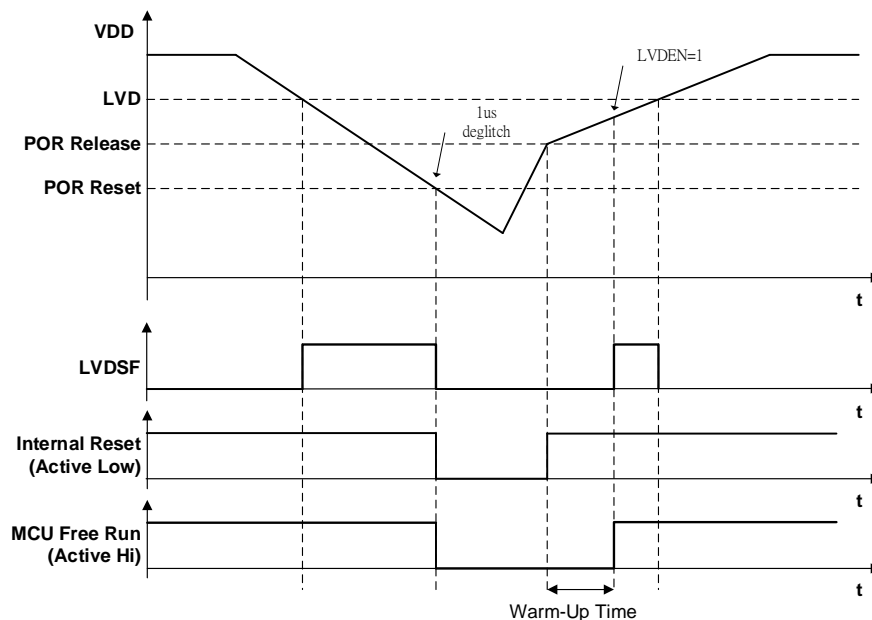

Figure 6-45 LVD waveform situation

6.13 Oscillator

6.13.1 Oscillator Modes

The EM88F752N can be operated in the five different oscillator modes, such as Internal RC oscillator mode (IRC) and XTAL oscillator mode (XT). User needs to set main-oscillator modes by selecting the OSC2~OSC0, and set sub-oscillator modes by selecting the FSS1~FSS0 in the CODE Option register to complete the overall oscillator mode setting. Tables 7, 8, and 9 depict how these four modes are defined.

The up-limited operation frequency of crystal/resonator on the different VDD is listed in Table 10.

Table 7 Main-oscillator modes defined by OSC[2:0]

Main-oscillator mode	OSC2	OSC1	OSC0
IRC (Internal RC oscillator mode) (default) RCOUT (P80) acts as I/O pin	0	0	0
IRC (Internal RC oscillator mode) RCOUT (P80) acts as clock output pin	0	0	1
HXT1 (High XTAL1 oscillator mode) Frequency range: 12~20MHz	0	1	0
HXT2(High XTAL2 oscillator mode) Frequency range: 6~12MHz	0	1	1
XT (XTAL oscillator mode) Frequency range: 1~6MHz	1	0	0
LXT1 (Low XTAL1 oscillator mode) Frequency range: 100K~1MHz	1	0	1
LXT2 (Low XTAL2 oscillator mode) Frequency range: 32.768kHz	1	1	0
Reserve	1	1	1

Table 8 Sub-oscillator modes defined by FSS1 ~ FSS0

Sub-oscillator Mode	FSS1	FSS0
LXT3 (Low XTAL3) oscillator mode Frequency range: 32.768kHz	1	x
Fs is 16kHz, Xin (P83) /Xout (P84) pin act as I/O (default)	0	0
Fs is 128kHz, Xin (P83) /Xout (P84) pin act as I/O	0	1

Note: WDT frequency is always 16kHz whenever the FSS[1:0] bits are set.

Table 9 Combination of main-oscillator and sub-oscillator modes

Combination	Main Clock	Sub-clock
1	Crystal	Crystal
2	Crystal	IRC
3	IRC	Crystal
4	IRC	IRC

Table 10 Summary of Maximum Operating Speeds

Conditions	VDD	F _{XT} max.(MHz)
Two cycles with two clocks	2.1	8.0
	3.5	16.0
	5.0	20.0

6.13.2 Internal RC Oscillator Mode

EM88F752N offer a versatile internal RC mode with default frequency value of 4MHz. Internal RC oscillator mode has other frequencies (20 MHz, 16 MHz, 12 MHz , 8 MHz, 6 MHz) that can be set by Code Option Bits RCM2 ~ RCM0.

Internal RC Drift Rate (Ta=25°C, VDD=5V±5%, VSS=0V)

Internal RC Frequency	Drift Rate			
	Temperature (-40°C~+85°C)	Voltage (2.1V~5.5V)	Process	Total
4MHz	±2%	±1%	±1%	±4%
6MHz	±2%	±1%	±1%	±4%
8MHz	±2%	±1%	±1%	±4%
12MHz	±2%	±1%	±1%	±4%
16MHz	±2%	±1%	±1%	±4%
20MHz	±2%	±1%	±1%	±4%

Note: Theoretical values are for reference only. Actual values may vary depending on actual process.

6.14 Power-on Considerations

Any microcontroller is not guaranteed to start to operate properly before the power supply has remained stabilized. The EM88F752N has an on-chip Power-on Voltage Detector (POVD) with a detecting level of 1.9V. It will work well if VDD is rising quick enough (50ms or less). In many critical applications, however, extra devices are still required to assist in solving power-up problems.

6.15 External Power-on Reset Circuit

The circuit as shown in Figure 6-41 implements an external RC to produce the reset pulse. The pulse width (time constant) should be kept long enough for VDD to reached minimum operation voltage. This circuit is used when the power supply has slow rise time. Because the current leakage from the /RESET pin is about $\pm 5\mu\text{A}$, it is recommended that R should not be greater than 40K. In this way, the /RESET pin voltage is held below 0.2V. The diode (D) acts as a short circuit at the moment of power down. The capacitor C will discharge rapidly and fully. Rin, the current-limited resistor, will prevent high current or ESD (electrostatic discharge) from flowing to pin /RESET.

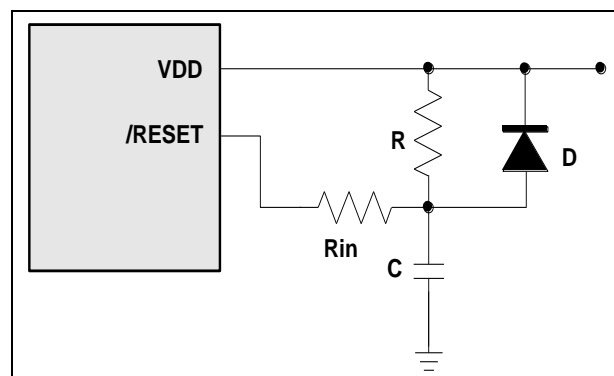

Figure 6-41 External Power-Up Reset Circuit

6.16 Residue-Voltage Protection

When battery is replaced, device power (VDD) is taken off but residue-voltage remains. The residue-voltage may trips below VDD minimum, but not to zero. This condition may cause a poor power on reset. Figure 6-42 and Figure 6-43 show how to build a residue-voltage protection circuit.

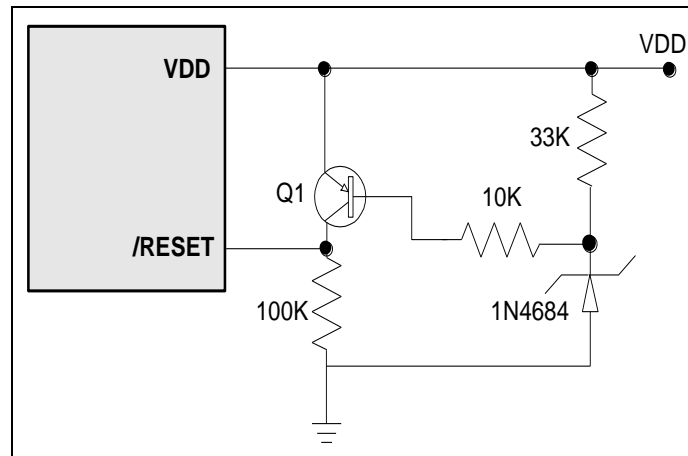

Figure 6-42 Circuit 1 for the Residue Voltage Protection

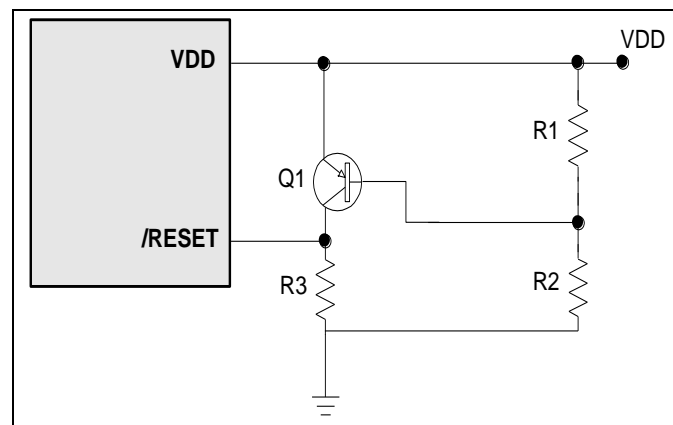

Figure 6-43 Circuit 2 for the Residue Voltage Protection

6.17 Code Option

6.17.1 Code Option Register (Word 0)

Word 0								
Mnemonic	Bit 15	Bit 14	Bit 13	Bit 12	Bit11	Bit10	Bit9	Bit8
	-	-	IRCWUT	IODG1	IODG0	HLFS	-	LVR1
1	High	High	32 clks	High	High	Green	High	High
0	Low	Low	8 clks	Low	Low	Normal	Low	Low
Default	0	0	0	0	0	0	0	0
Mnemonic	Bit 7	Bit 6	Bit 5	Bit 4	Bit 3	Bit 2	Bit 1	Bit 0
	LVR0	RESETEN	ENWDT	NRHL	NRE	-	-	-
1	High	/RST	Enable	8/fc	Disable	High		
0	Low	P82	Disable	32/fc	Enable	Low		
Default	0	0	0	0	0	0		

Bits 15~14: Not used, set to "0" all the time.

Bit 13 (IRCWUT): IRC Warm-up Time(IRC Frequency Range 1 MHz ~8 MHz)

0: 8 clocks (default)

1: 32 clocks

CPU mode switch	IRC Frequency	Waiting Time before CPU Startsto Work
Sleep → Normal Idle → Normal	12M, 16M, 20M	WSTO + 32 clocks (main frequency)
Green → Normal	4M, 6M, 8M	WSTO + 8/32 clocks (main frequency)
Sleep → Green Idle → Green	128kHz	WSTO + 8 clocks (sub frequency)

Bits 12~11 (IODG1~IODG0): I2C pin deglitch time select bits.

IODG1~0	SPI Pin Deglitch Time	I2C Pin Deglitch Time	OCDS Pin Deglitch Time
00	Typical delay = 8ns	50ns@5V, Typical (default)	20ns@5V, Typical(default)
01	Typical delay = 15ns	100ns@5V, Typical	
10	Typical delay = 25ns	150ns@5V, Typical	
11	No deglitch	No deglitch	No deglitch

Bit 10 (HLFS): Reset to Normal or Green Mode Select Bit

0: CPU is selected as Normal mode when a reset occurs (default)

1: CPU is selected as Green mode when a reset occurs.

Bits 9: Not used, set to "0" all the time.

Bits 8~7 (LVR1~LVR0): Low Voltage Reset enable bit.

LVR1, LVR0	VDD Reset Level	VDD Release Level
00	NA (Power on reset) (default)	
01	2.7V	2.9V

Note: If VDD < 2.7V and keep about 5μs, IC will be reset.

Bit 6 (RESETEN): P82/RESET pin selection bit

0: Disable, P82 as I/O pin (default)

1: Enable, P82 as RESET pin.

Bit 5 (ENWDT): WDT enable bit

0: Disable (default)

1: Enable

Bit 4 (NRHL): Noise rejection high/low pulse define bit (For the INT Pin)

0: pulses equal to 32/Fc [s] is regarded as signal (default)

1: pulses equal to 8/Fc [s] is regarded as signal

<Note> In Low XTAL oscillator (LXT) mode the noise rejection high/low pulses always 8/Fm.

Bit 3 (NRE): Noise Rejection Enablebit

0: Enable (default) .But in Green, Idle, and Sleep modes, the noise rejection circuit is always disabled.

1: Disable

Bits 2~0: Not used, set to "0" all the time.

6.17.2 Code Option Register (Word 1)

Word 1								
Mnemonic	Bit 15	Bit 14	Bit 13	Bit 12	Bit11	Bit10	Bit9	Bit8
	-	FSS1	FSS0	-	-	-	-	-
1	High	High	High	High	High	High	High	High
0	Low	Low	Low	Low	Low	Low	Low	Low
Default	0	0	0	0	0	0	0	0
Mnemonic	Bit 7	Bit 6	Bit 5	Bit 4	Bit 3	Bit 2	Bit 1	Bit 0
	-	RCM2	RCM1	RCM0	OSC2	OSC1	OSC0	RCOUT
1	High	High	High	High	High	High	High	High
0	Low	Low	Low	Low	Low	Low	Low	Low
Default	0	0	0	0	0	0	0	0

Bit 15: Not used, set to "0" all the time.

Bits 14~13 (FSS1~FSS0): Sub-oscillator mode selection bits

Sub-oscillator mode	FSS1	FSS0
LXT3 (Low XTAL3) oscillator mode Frequency range: 32.768kHz	1	x
Fs is 16kHz, Xin (P83) / Xout (P84) pin act as I/O (default)	0	0
Fs is 128kHz, Xin (P83) / Xout (P84) pin act as I/O	0	1

Note: WDT frequency is always 16kHz, whatever the FSS bits are set.

Bits 12~7: Not used, set to "0" all the time.

Bits 6~4 (RCM2~RCM0): IRC frequency selection.

* Corresponding with control register Bank0 RE RCM2~RCM0

RCM2	RCM1	RCM0	Frequency (MHz)
0	0	0	4(default)
0	0	1	NA
0	1	0	6
0	1	1	8
1	0	0	12
1	0	1	16
1	1	0	20
1	1	1	N/A

Bits 3~1 (OSC2~OSC0): Main-oscillator mode selection bits.

Main-oscillator mode	OSC2	OSC1	OSC0
IRC (Internal RC oscillator mode) (default) RCOUT (P80) acts as I/O pin	0	0	0
IRC (Internal RC oscillator mode) RCOUT (P80) acts as clock output pin	0	0	1
HXT1 (High XTAL1 oscillator mode) Frequency range: 12~20MHz	0	1	0
HXT2(High XTAL2 oscillator mode) Frequency range: 6~12MHz	0	1	1
XT (XTAL oscillator mode) Frequency range: 1~6MHz	1	0	0
LXT1 (Low XTAL1 oscillator mode) Frequency range: 100K~1MHz	1	0	1
LXT2 (Low XTAL2 oscillator mode) Frequency range: 32.768kHz	1	1	0
Reserve	1	1	1

Bit 0 (RCOUT): System Clock Output Enable Bit in IRC mode

0: RCOUT output instruction cycle time (default)

1: RCOUT pin is open drain

6.17.3 Code Option Register (Word 2)

Word 2								
Mnemonic	Bit 15	Bit 14	Bit 13	Bit 12	Bit11	Bit10	Bit9	Bit8
	-	SHEN	-	-	-	-	-	-
1	High	Disable	-	-	-	-	-	-
0	Low	Enable	-	-	-	-	-	-
Default	0	0	0	0	0	0	0	0
Mnemonic	Bit7	Bit6	Bit5	Bit4	Bit3	Bit2	Bit1	Bit0
	IRCPSS	-	-	I2COPT	-	-	-	-
1	VDD	-	-	High	-	-	-	-
0	Int. Vref	-	-	Low	-	-	-	-
Default	0	0	0	0	0	0	0	0

Bit 15: Not used, set to "0" all the time.

Bit 14 (SHEN): System hold enable bit.

- 0: Enable
- 1: Disable

Bits 13~8: Not used, set to "0" all the time.

Bit 7 (IRCPSS):IRC Power Source Selection

- 0: Internal reference (default)
- 1: VDD

Bits 6~5: Not used, set to "0" all the time.

Bit 4 (I2COPT): I2C optional bit. It is used to switch the pin position of I2C function.

- 0: Placed I2C pins in P62 (SDA0) and P82 (SCL0) (default)
- 1: Placed I2C pins in P84 (SDA1) and P83 (SCL1).

*Corresponding with control register Bank0 R31 I2COPT

Bits 3~0: Not used, set to "0" all the time.

6.17.4 Code Option Register (Word 3)

Word 3								
Mnemonic	Bit 15	Bit 14	Bit 13	Bit 12	Bit11	Bit10	Bit9	Bit8
	-	EFTIM	-	-	ADFM	-	-	-
1	High	Heavy	High	High	High	High	High	High
0	Low	Light	Low	Low	Low	Low	Low	Low
Default	0	0	0	0	0	0	0	0
Mnemonic	Bit7	Bit6	Bit5	Bit4	Bit3	Bit2	Bit1	Bit0
	-	TBWN	ID5	ID4	ID3	ID2	ID1	ID0
1	High	Enable	Customer ID					
0	Low	Disable						
Default	0	0						

Bit 15: Not used, set to "0" all the time.

Bit 14 (EFTIM): Low Pass Filter (0: heavy, 1: light)

0: Pass ~ 25 MHz (light LPS) (default)

1: Pass ~ 10 MHz (heavy LPS)

Bits 13~12: Not used, set to "0" all the time.

Bit 11 (ADFM): This bit controls the format of AD data buffer (ADDH and ADDL), Refer to the following table

ADFM		Bit 7	Bit 6	Bit 5	Bit 4	Bit 3	Bit 2	Bit 1	Bit 0	
12 bits	0	ADDH					ADD11	ADD10	ADD9	ADD8
		ADDL	ADD7	ADD6	ADD5	ADD4	ADD3	ADD2	ADD1	ADD0
	1	ADDH	ADD11	ADD10	ADD9	ADD8	ADD7	ADD6	ADD5	ADD4
		ADDL					ADD3	ADD2	ADD1	ADD0

Note: *There is no use to have the hardware bit set to 0. As ADFM=0 and when 12-bit resolution, ADDH<7:4> = 0000.*

Bits 10~7: Not used, set to "0" all the time.

Bit 6 (TBWEN): Table Write Enable bit.

0: Disable (default)

1: Enable

Bits 5~0 (ID5~ID0): Customer's ID Code

6.18 Instruction Set

Each instruction in the instruction set is a 15-bit word divided into an OP code and one or more operands. Normally, all instructions are executed within one single instruction cycle (one instruction consists of 2 oscillator periods), unless the program counter is changed by instruction "MOV R2,A", "ADD R2,A", or by instructions of arithmetic or logic operation on R2 (e.g. "SUB R2,A", "BS(C) R2,6", "CLR R2",). In this case, the execution takes two instruction cycles.

If for some reasons, the specification of the instruction cycle is not suitable for certain applications, try modifying the instruction as follows:

"LCALL", "LJMP", or the conditional skip ("JBS", "JBC", "JZ", "JZA", "DJZ", "DJZA", "SJC", "SJNC", "SJZ", "SJNZ") commands which were tested to be true, are executed with in two instruction cycles.

In addition, the instruction set has the following features:

- (1) Every bit of any register can be set, cleared, or tested directly.
- (2) The I/O register can be regarded as general register. That is, the same instruction can operate on I/O register.

The symbol "R" represents a register designator that specifies which one of the registers (including operational registers and general purpose registers) is to be utilized by the instruction. "b" represents a bit field designator that selects the value for the bit which is located in the register "R", and affects operation. "k" represents an 8 or 10-bit constant or literal value.

Mnemonic	Operation	Status Affected
NOP	No Operation	None
DAA	Decimal Adjust A	C
SLEP	0 → WDT, Stop oscillator	T,P
WDTC	0 → WDT	T,P
ENI	Enable Interrupt	None
DISI	Disable Interrupt	None
RET	[Top of Stack] → PC	None
RETI	[Top of Stack] → PC, Enable Interrupt	None
RESET	Software Device Reset	ALL Registers = Reset Value Flags* = Reset Value

Mnemonic	Operation	Status Affected
TBWR	Table Writer Start instruction	None
INT k	PC+1 → [SP], k*2 → PC	None
BTG R,b	Bit Toggle R ; /(R)->R *Range R5~RA	None
MOV R,A	A → R	None
CLRA	0 → A	Z
CLR R	0 → R	Z
SUB A,R	R-A → A	Z, C, DC, OV, N
SUB R,A	R-A → R	Z, C, DC, OV, N
DECA R	R-1 → A	Z, C, DC, OV, N
DEC R	R-1 → R	Z, C, DC, OV, N
OR A,R	A ∨ R → A	Z, N
OR R,A	A ∨ R → R	Z, N
AND A,R	A & R → A	Z, N
AND R,A	A & R → R	Z, N
XOR A,R	A ⊕ R → A	Z, N
XOR R,A	A ⊕ R → R	Z, N
ADD A,R	A + R → A	Z, C, DC, OV, N
ADD R,A	A + R → R	Z, C, DC, OV, N
MOV A,R	R → A	Z
MOV R,R	R → R	Z
COMA R	/R → A	Z, N
COM R	/R → R	Z, N
INCA R	R+1 → A	Z, C, DC, OV, N
INC R	R+1 → R	Z, C, DC, OV, N
DJZA R	R-1 → A, skip if zero	None
DJZ R	R-1 → R, skip if zero	None
RRCA R	R(n) → A(n-1), R(0) → C, C → A(7)	C, N
RRC R	R(n) → R(n-1), R(0) → C, C → R(7)	C, N
RLCA R	R(n) → A(n+1), R(7) → C, C → A(0)	C, N

Mnemonic	Operation	Status Affected
RLC R	$R(n) \rightarrow R(n+1)$, $R(7) \rightarrow C$, $C \rightarrow R(0)$	C,N
SWAPA R	$R(0-3) \rightarrow A(4-7)$, $R(4-7) \rightarrow A(0-3)$	None
SWAP R	$R(0-3) \leftrightarrow R(4-7)$	None
JZA R	$R+1 \rightarrow A$, skip if zero	None
JZ R	$R+1 \rightarrow R$, skip if zero	None
BC R,b	$0 \rightarrow R(b)$	None <Note2>
BS R,b	$1 \rightarrow R(b)$	None <Note3>
JBC R,b	if $R(b)=0$, skip	None
JBS R,b	if $R(b)=1$, skip	None
CALL k	$PC+1 \rightarrow [SP]$, (Page, k) $\rightarrow PC$	None
JMP k	(Page, k) $\rightarrow PC$	None
MOV A,k	$k \rightarrow A$	None
JE R	Compare R with ACC, Skip =	None
JGE R	Compare R with ACC, Skip >	None
JLE R	Compare R with ACC Skip <	None
OR A,k	$A \vee k \rightarrow A$	Z, N
JE k	Compare K with ACC, Skip =	None
TBRDA R	$ROM[(TABPTR)] \rightarrow R$, A $A \leftarrow$ program code (low byte) ; $R \leftarrow$ program code (high byte)	None
AND A,k	$A \& k \rightarrow A$	Z, N
SJC k	Jump to K if Carry *Range [Address+127~-128]	None
SJNC k	Jump to K if Not Carry *Range [Address+127~-128]	None
SJZ k	Jump to K if Zero *Range [Address+127~-128]	None
XOR A,k	$A \oplus k \rightarrow A$	Z, N
SJNZ k	Jump to K if Not Zero *Range [Address+127~-128]	None

Mnemonic	Operation	Status Affected
RRA R	$R(n) \rightarrow A(n-1), R(0) \rightarrow A(7)$	N
RR R	$R(n) \rightarrow R(n-1), R(0) \rightarrow R(7)$	N
RETL k	$k \rightarrow A,$ $[Top\ of\ Stack] \rightarrow PC$	None
XCH R	$R \leftrightarrow A$	None
RLA R	$R(n) \rightarrow A(n+1), R(7) \rightarrow A(0)$	N
RL R	$R(n) \rightarrow R(n+1), R(7) \rightarrow R(0)$	N
SUB A,k	$k-A \rightarrow A$	Z, C, DC, OV, N
SUBB A,R	$R-A/C \rightarrow A$	Z, C, DC, OV, N
SUBB R,A	$R-A/C \rightarrow R$	Z, C, DC, OV, N
SBANK k	$K \rightarrow R1(5:4)$	None
GBANK k	$K \rightarrow R1(0)$	None
LCALL k	Next instruction : k kkkkkkkkkkkk $PC+1 \rightarrow [SP], k \rightarrow PC$	None
LJMP k	Next instruction : k kkkkkkkkkkkk $K \rightarrow PC$	None
TBRD R	$ROM[(TABPTR)] \rightarrow R$	None
ADD A,k	$k+A \rightarrow A$	Z, C, DC, OV, N
NEG R	2's complement, $/R +1 \rightarrow R$	Z, C, DC, OV, N
ADC A,R	$A+R+C \rightarrow A$	Z, C, DC, OV, N
ADC R,A	$A+R+C \rightarrow R$	Z, C, DC, OV, N

7 Absolute Maximum Ratings

Items	Rating		
Storage temperature	-65°C	to	150°C
Input voltage	V _{ss} -0.3V	to	V _{dd} +0.5V
Output voltage	V _{ss} -0.3V	to	V _{dd} +0.5V
Working Voltage	2.1V ⁽¹⁾	to	5.5V
	2.4V ⁽²⁾	to	5.5V
Working Frequency	DC	to	20 MHz

⁽¹⁾2.1V~5.5V at 0°C ~70°C (Commercial)

⁽²⁾2.4V~5.5V at -40°C ~85°C (Industrial)

8 DC Electrical Characteristics

V_{DD}=5.0V, V_{SS}=0V, T_a=25°C

Symbol	Parameter	Condition	Min.	Typ.	Max.	Unit
Fxt	XTAL: VDD to 3V	Two cycles with two clocks	DC	16	–	MHz
	XTAL: VDD to 5V		DC	20	–	MHz
	IRC: VDD to 5V	4 MHz, 1 MHz, 6MHz, 8MHz, 16 MHz, 20 MHz	–	F	–	Hz
IRCE	Internal RC oscillator error per stage	–	–	±1	–	%
IRC1	IRC:VDD to 5V	RCM2~RCM0=000	–	4	–	MHz
IRC2	IRC:VDD to 5V	RCM2~RCM0=001	–	1	–	MHz
IRC3	IRC:VDD to 5V	RCM2~RCM0=010	–	6	–	MHz
IRC4	IRC:VDD to 5V	RCM2~RCM0=011	–	8	–	MHz
IRC5	IRC:VDD to 5V	RCM2~RCM0=100	–	12	–	MHz
IRC6	IRC:VDD to 5V	RCM2~RCM0=101	–	16	–	MHz
IRC7	IRC:VDD to 5V	RCM2~RCM0=110	–	20	–	MHz
IIL	Input Leakage Current for input pins	V _{IN} = V _{DD} , V _{SS}	-1	0	1	μA
VIH1	Input High Voltage (Schmitt trigger)	Ports 5, 6, 7, 8, 9, A	0.7V _{DD}	–	V _{DD} +0.3V	V
VIL1	Input Low Voltage (Schmitt trigger)	Ports 5, 6, 7, 8, 9, A	-0.3V	–	0.3V _{DD}	V
VIHT1	Input High Threshold Voltage (Schmitt trigger)	/RESET	0.7V _{DD}	–	V _{DD} +0.3V	V
VILT1	Input Low Threshold Voltage (Schmitt trigger)	/RESET	-0.3V	–	0.3V _{DD}	V
IOH1	Output High Voltage (Ports 5, 6, 7, 8, 9, A)	VOH = V _{DD} -0.1V _{DD}	-2.6	-3.7	–	mA
	Output High Voltage (Ports 5, 6, 8, 9, A)	VOH = V _{DD} -0.3V _{DD}	–	-8	–	mA
IOH2	Output High Voltage(Hi Drive) (Ports 5, 6, 8)	VOH = V _{DD} -0.1V _{DD}	-7.3	-11	–	mA
	Output High Voltage(Hi Drive) (Ports 5, 6, 8)	VOH = V _{DD} -0.3V _{DD}	–	-24	–	mA
IOL1	Output Low Voltage (Ports 5, 6, 8)	VOL = GND+0.1V _{DD}	12.6	18	–	mA
	Output Low Voltage (Ports 5, 6, 8)	VOL = GND+0.3V _{DD}	–	32	–	mA

Symbol	Parameter	Condition	Min.	Typ.	Max.	Unit
IOL2	Output Low Voltage(Hi Sink) (Ports 50-57, 60)	VOL = GND+0.1VDD	28	41	–	mA
	Output Low Voltage(Hi Sink) (Ports 61-64, 80-84)		35	50	–	mA
	Output Low Voltage(Hi Sink) (Ports 50-57, 60)	VOL = GND+0.3VDD	–	90	–	mA
	Output Low Voltage(Hi Sink) (Ports 61-64, 80-84)		–	100	–	mA
IPH	Pull-high current	Pull-high active, input pin at VSS	33	51.5	70	μA
IPL	Pull-low current	Pull-low active, input pin at VDD	11	17	23	μA
LVR1	Low voltage reset level	TA = 25°C	2.26	2.7	3.16	V
		TA = -40~85°C	1.86	2.7	3.56	V
ISB1	Power down current (Sleep mode)	/RESET= 'High', Fm& Fs off All input and I/O pins at VDD, output pin floating, WDT disabled	–	1	–	μA
ISB2	Power down current (Sleep mode)	/RESET= 'High', Fm& Fs off All input and I/O pins at VDD, output pin floating, WDT enabled	–	5	–	μA
ISB3	Power down current (Idle mode)	/RESET= 'High', Fm off, Fs=128kHz (IRC type) output pin floating, WDT disabled,	–	7.5	–	μA
ISB4	Power down current (Idle mode)	/RESET= 'High', Fm off, Fs=128kHz (IRC type), output pin floating, WDT enabled	–	7.5	–	μA
ICC1	Operating supply current (Green mode)	/RESET= 'High', Fm off, Fs=128KHz (IRC type), output pin floating, WDT disabled	–	90	–	μA
ICC2	Operating supply current (Green mode)	/RESET= 'High', Fm off, Fs=128kHz (IRC type), output pin floating, WDT enabled	–	90	–	μA
ICC3	Operating supply current (Green mode)	/RESET= 'High', Fm off, HLP=0, Fs=32.768KHz (Crystal type), output pin floating, WDT enabled	–	30	–	μA
ICC4	Operating supply current (Normal mode)	/RESET= 'High', Fm=4 MHz (IRC type), Fs on, output pin floating, WDT enabled	–	1200	–	μA
ICC5	Operating supply current (Normal mode)	/RESET= 'High', Fm=4 MHz (Crystal type), Fs on, output pin floating, WDT enabled	–	1500	–	μA
ICC6	Operating supply current (Normal mode)	/RESET= 'High', Fm=12 MHz (IRC type), Fs on, output pin floating, WDT enabled	–	3000	–	μA
ICC7	Operating supply current (Normal mode)	/RESET= 'High', Fm=16 MHz (IRC type), Fs on, output pin floating, WDT enabled	–	3700	–	μA
ICC8	Operating supply current (Normal mode)	/RESET= 'High', Fm=16 MHz (Crystal type), Fs on, output pin floating, WDT enabled	–	5000	–	μA

Note: These parameters are theoretical values and have not been tested. Such parameters are for design reference only.

Data in the Minimum, Typical, Maximum (“Min.,” “Typ.,” “Max.”) columns are based on characterization results at 25°C.

Program Flash Memory Electrical Characteristics (VDD=2.4V to 5.5V, VSS=0V, Ta=-40 to 85°C)

Symbol	Parameter	Condition	Min.	Typ.	Max.	Unit
Tprog	Erase/Write cycle time	Vdd = 5.0V	-	2	3	ms
Treten	Data Retention		-	10	-	Years
Tendu	Endurance time		-	100K	-	Cycles

A/D Converter Characteristics (VDD=2.4V to 5.5V, VSS=0V, Ta=-40 to 85°C)

Symbol	Parameter	Condition	Min.	Typ.	Max.	Unit
Operating Range	Vdd	For 5.5V Fs=100kHz, Fin=2kHz, For 2.4VFs=50kHz, Fin=1kHz	2.4	-	5.5	V
	V _{REFT}		2.4	-	Vdd	V
1/2 *VDD AD Input	V _{1/2VDD}	Vdd=5V	2.475	2.5V	2.525	V
	T _{1/2VDD}	Vdd=5V		2.8	4	μS
	I _{1/2VDD}	Vdd=5V		35	42	μA
Current Consumption	I _{vdd}	V _{REFT} =Vdd=5.5v, Fs=100kHz, Fin=2kHz	-	-	0.7	mA
	I _{ref}		-	-	1	μA
Standby Current	I _{sb}		-	-	0.1	μA
ZAI	ZAI		-	-	10k	Ω
SNR	SNR	V _{REFT} =Vdd=3.3V Fs=100kHz, Fin=2kHz	70	-	-	dBc
THD	THD	V _{REFT} =Vdd=3.3V Fs=100kHz, Fin=2kHz	-	-	-70	dBc
SNDR	SNDR	V _{REFT} =Vdd=3.3V, Fs=100kHz, Fin=2kHz	68	-	-	dBc
Worst Harmonic	WH	V _{REFT} =Vdd=3.3V Fs=100kHz, Fin=2kHz	-	-	-73	dBc
SFDR	SFDR	V _{REFT} =Vdd=3.3V, Fs=100kHz, Fin=2kHz	73	-	-	dBc
Offset Error	OE	V _{REFT} =Vdd=3.3V Fs=100kHz	-	-	±4	LSB
Gain Error	GE	V _{REFT} =Vdd=3.3V Fs=100kHz	-	-	±8	LSB
DNL	DNL	V _{REFT} =Vdd=3.3V Fs=100kHz, Fin=2kHz	-	-	±1	LSB
INL	INL	V _{REFT} =Vdd=3.3V Fs=100kHz, Fin=2kHz	-	-	±4	LSB
Conversion Rate	Fs1	Vdd=2.7~5.5V, Fin=2kHz	100	-	-	KSPS
	Fs2	Vdd=2.2~2.7V, (Ta = 0 to 70°C) Fin=1kHz	50	-	-	KSPS
	Fs3	Vdd=2.1~2.2V, (Ta = 0 to 70°C) Fin=1kHz	25	-	-	KSPS
Power Supply Rejection Ratio	PSRR	V _{REFT} =2.1V Vdd=2.1V ~ 5.5V Fs=50kHz, Vin=0V ~ 2.1V (Ta = 0 to 70°C)	-	-	2	LSB

Note:¹ These parameters are hypothetical(not tested) and are provided for design reference only.

² There is no current consumption when ADC is off other than minor leakage current.

³ The A/D conversion result will not decrease with an increase in the input voltage, and has no missing code.

⁴These parameters are subject to change without prior notice.

9 AC Electrical Characteristics

EM88F752N, (-40≤Ta≤85°C, VDD=5V, VSS=0V)

Symbol	Parameter	Conditions	Min.	Typ.	Max.	Unit
Dclk	Input CLK duty cycle	–	45	50	55	%
Tins	Instruction cycle time	Crystal type	100	–	DC	ns
		RC type	100	–	DC	ns
Ttcc	TCC input period	–	(Tins+20)/N*	–	–	ns
Tdrh	Device reset hold time	–	11.8	16.8	21.8	ms
Trst	/RESET pulse width	Ta = 25°C	2000	–	–	ns
Twdt	Watchdog timer period	Ta = 25°C	11.8	16.8	21.8	ms
Tset	Input pin setup time	–	–	0	–	ns
Thold	Input pin hold time	–	–	20	–	ns
Tdelay	Output pin delay time	Cload=20pF	–	50	–	ns

Note: These parameters are theoretical values and have not been tested. Such parameters are for design reference only.

Data in the Minimum, Typical, Maximum(“Min.”, “Typ.”, “Max.”) columns are based on characterization results at 25°C.

*N = selected prescaler ratio

External crystal oscillator Characteristics

(VDD=3V to 5.5V, VSS=0V, Ta=-40 to 85°C)

Symbol	Parameter	Condition	Min.	Typ.	Max.	Unit
Cload	Functional Capacitance	Typical Value	-	30	-	pF
VOUT_DUTY	Output Duty Ratio		40		60	%

APPENDIX

A Ordering and Manufacturing Information

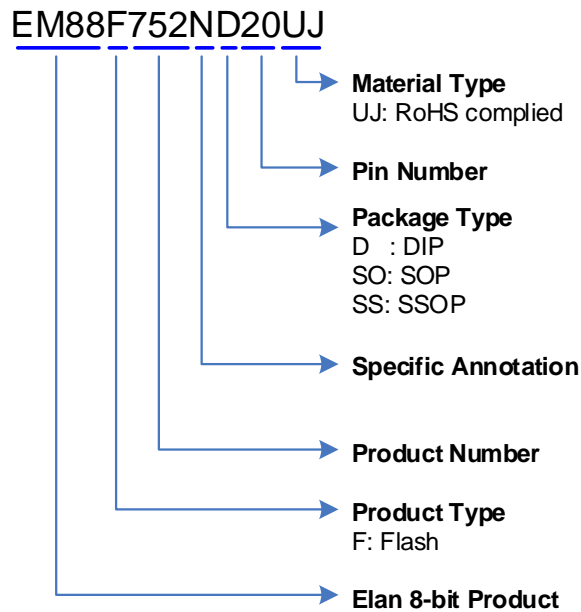

For example:

EM88F752ND20UJ

is EM88F752N with Flash program memory, industrial grade product, in 20-pin DIP package with RoHS complied

IC Mark

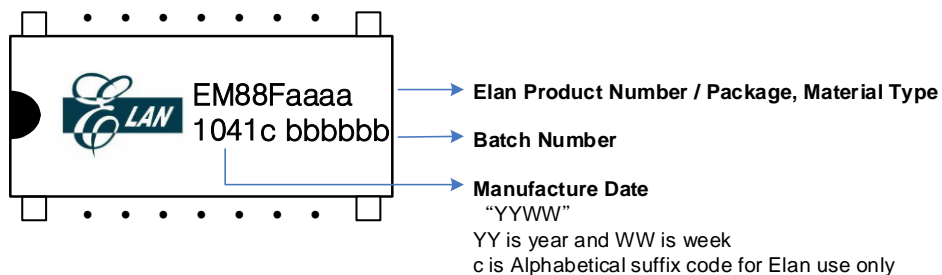

Ordering Code

EM88F752ND20UJ

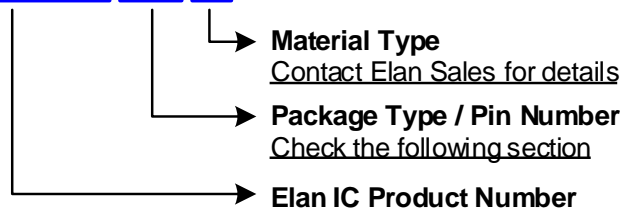

B Package Type

Flash MCU	Package Type	Pin Count	Package Size
EM88F752NSO20	SOP	20	300mil
EM88F752ND20	DIP	20	300mil
EM88F752NSS20	SSOP	20	209mil
EM88F752ND16 / AD16	DIP	16	300mil
EM88F752NSS16 / ASS16	SSOP	16	150mil
EM88F752NSO16 / ASO16	SOP	16	150mil

For Product Code “J” or “U”.

These are Green products and comply with RoHS specifications.

Part No.	EM88F752NxJ
Electroplate type	Pure Tin
Ingredient (%)	Sn: 100%
Melting point (°C)	232°C
Electrical resistivity ($\mu\Omega$ -cm)	11.4
Hardness (hv)	8~10
Elongation (%)	>50%

C Package Information

C.1 EM88F752NSO20

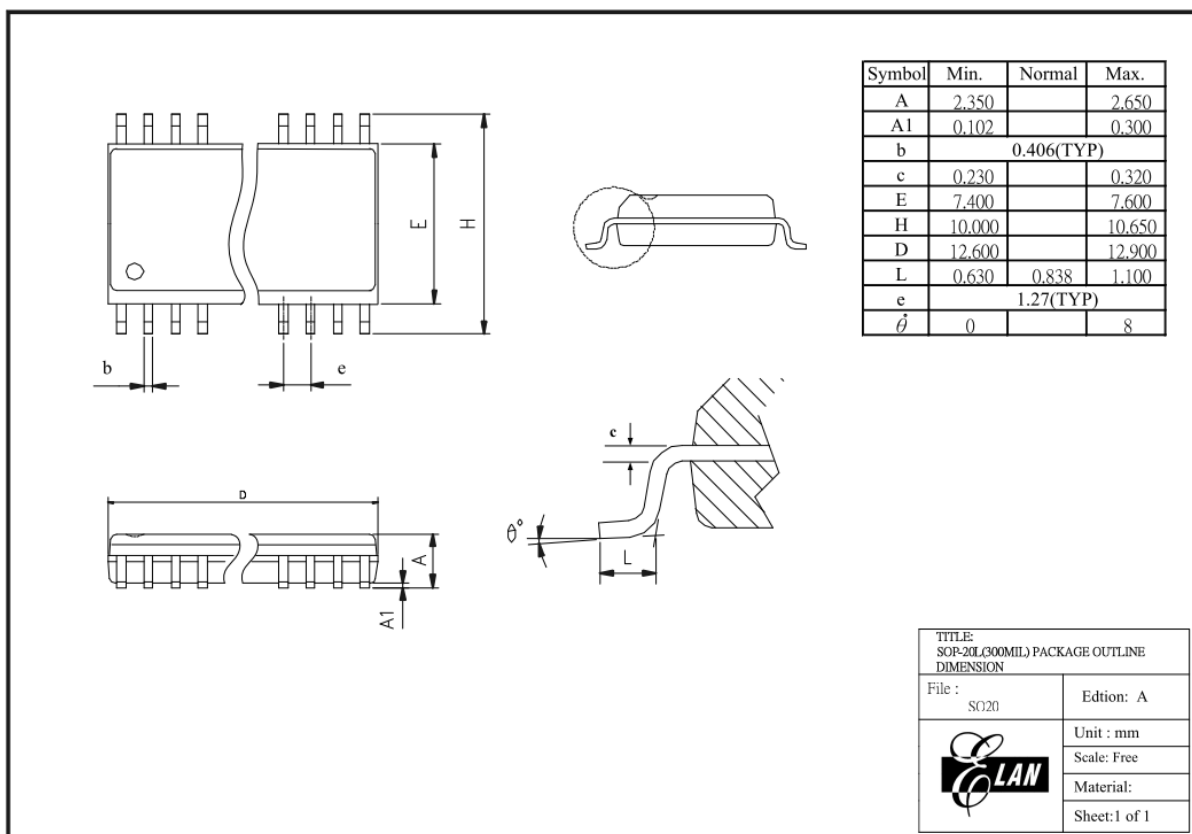

Figure C-1 EM88F752N20-pin SOP Package Type

C.2 EM88F752ND20

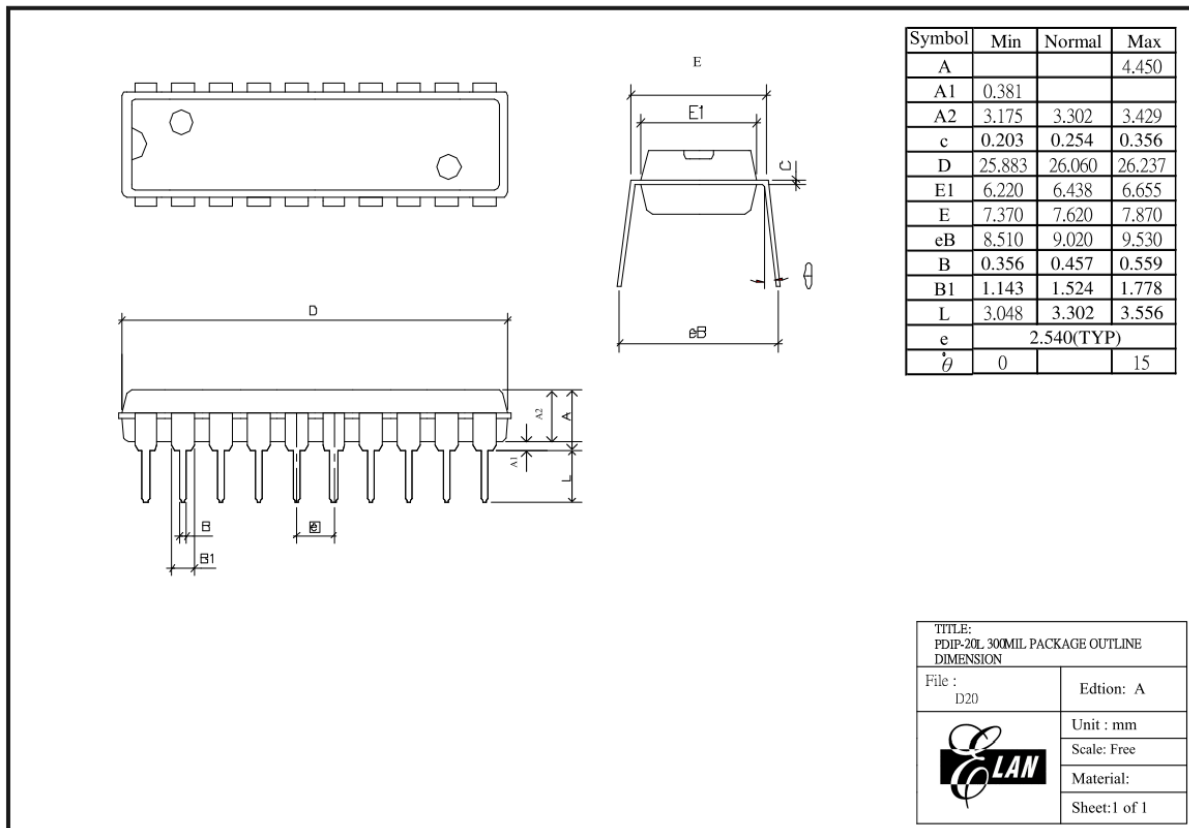

Figure C-2 EM88F752N20-pin DIP Package Type

C.3 EM88F752NSS20

Figure C-3 EM88F752N20-pin SSOP Package Type

C.4 EM88F752ND16/AD16

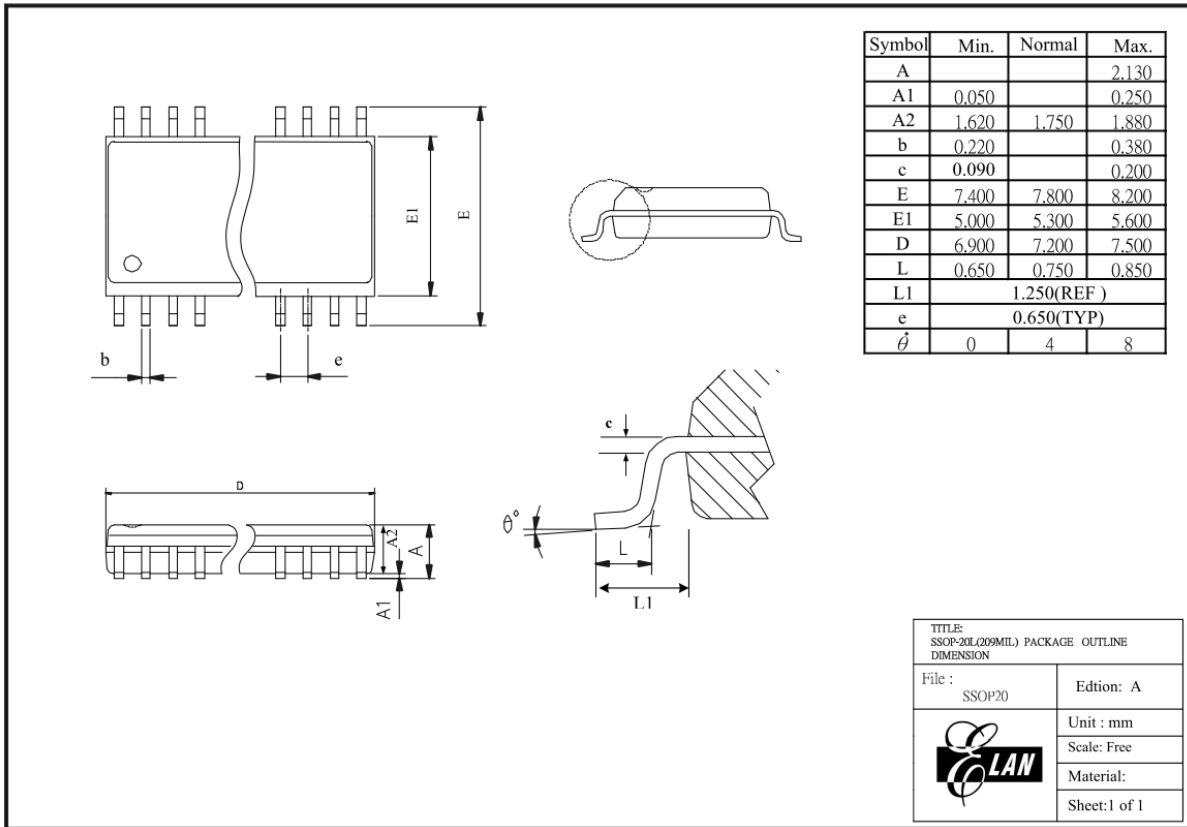
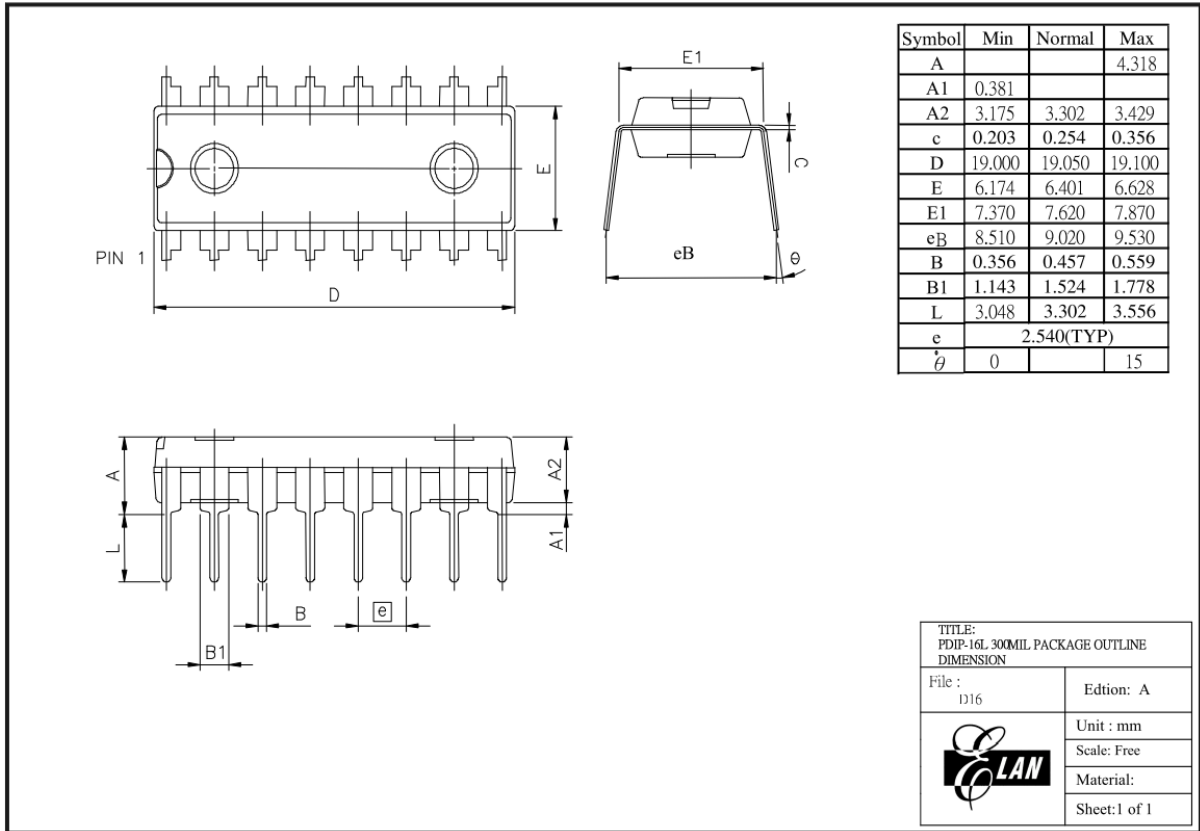

Figure C-4 EM88F752N16-pin DIP Package Type

C.5 EM88F752NSO16/ASO16

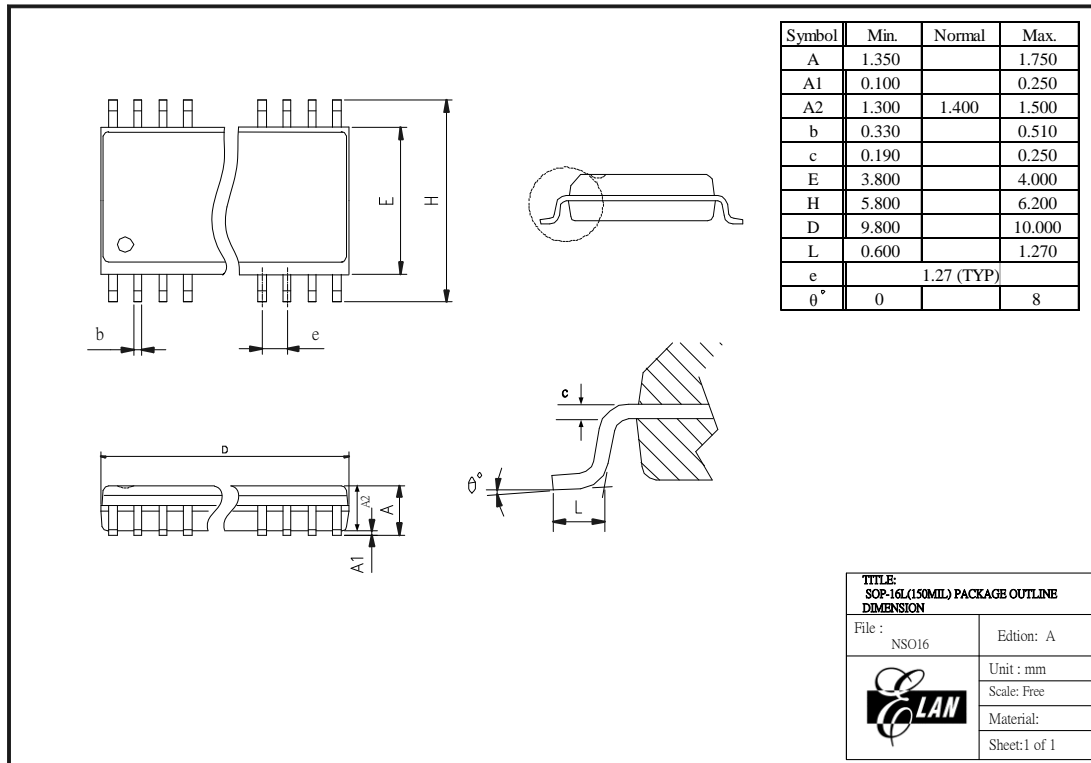

Figure C-5 EM88F752N16-pin SOP Package Type

C.6 EM88F752NSS16/ASS16

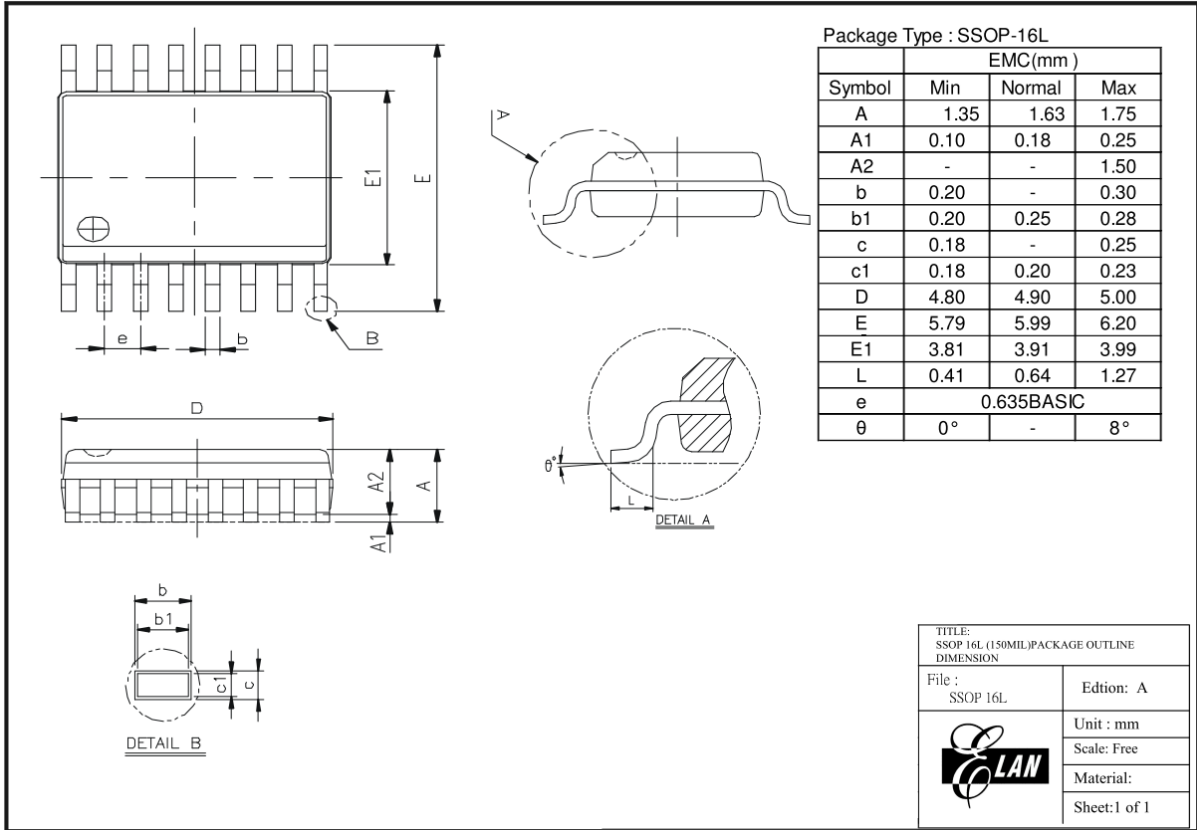

Figure C-6 EM88F752N16-pin SSOP Package Type

D Quality Assurance and Reliability

Test Category	Test Conditions	Remarks
Solderability	Solder temperature=245±5°C, for 5 seconds up to the stopper using a rosin-type flux	
Pre-condition	Step 1: TCT, 65°C(15 min)~150°C(15 min), 10 cycles	For SMD IC(such as SOP, QFP, SOJ, etc)
	Step 2: Bake at 125°C, TD (endurance)=24 hrs	
	Step 3: Soak at 30°C/60% , TD (endurance)=192hrs	
	Step 4: IR flow 3cycles (Pkg thickness ≥ 2.5mm or Pkg volume ≥ 350 mm ³ ----225±5°C) (Pkg thickness ≤ 2.5 mm or Pkg volume ≤ 350 mm ³ ----240±5°C)	
Temperature cycle test	-65°C (15mins)~150°C(15min), 200 cycles	
Pressure cooker test	TA =121°C,RH=100%,pressure = 2atm, TD (endurance)= 96 hrs	
High temperature / High humidity test	TA=85°C , RH=85% , TD (endurance)=168 ,500 hrs	
High-temperature storage life	TA=150°C, TD (endurance)=500, 1000 hrs	
High-temperature operating life	TA=125°C, VDD=Max. operating voltage, TD (endurance)=168, 500, 1000 hrs	
Latch-up	TA=25°C, VDD=Max. operating voltage, 800mA/40V	
ESD (HBM)	TA=25°C, ≥ ± 4KV	IP_ND,OP_ND,IO_ND IP_NS,OP_NS,IO_NS
ESD (MM)	TA=25°C, ≥ ± 400V	IP_PD,OP_PD,IO_PD, IP_PS,OP_PS,IO_PS, VDD-VSS(+), VDD_VSS(-)mode

D.1 Address Trap Detect

An address trap detect is one of the MCU embedded fail-safe functions that detects MCU malfunction caused by noise or the like. Whenever the MCU attempts to fetch an instruction from a certain section of ROM, an internal recovery circuit is auto started. If a noise caused address error is detected, the MCU will repeat execution of the program until the noise is eliminated. The MCU will then continue to execute the next program.

E EM88F752N Program Pin List

UWTR is used to program the EM88F752N IC's. The UWTR connector is selected through Table E-1. The software is selected by EM88F752N.

UWTR-ADP		UWTR-ADP109	UWTR-ADP112	UWTR-ADP113
Program Pin Name	IC Pin Name	EM88F752NSO20 /D20/SS20 Pin Number	EM88F752NSO16 /D16/SS16 Pin Number	EM88F752NASO16 /D16/SS16 Pin Number
2W_SCL	P64	7	7	5
2W_SDA	P63	8	8	6
VDD	VDD	20	16	16
VSS	VSS	1	1	1

TableE-1EM88F752N Program Pin List